

# Equalizing Bearings

Marine Type and Heavy Industrial  
Mountings - Catalog LH

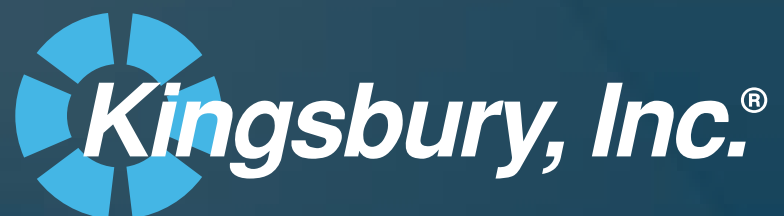

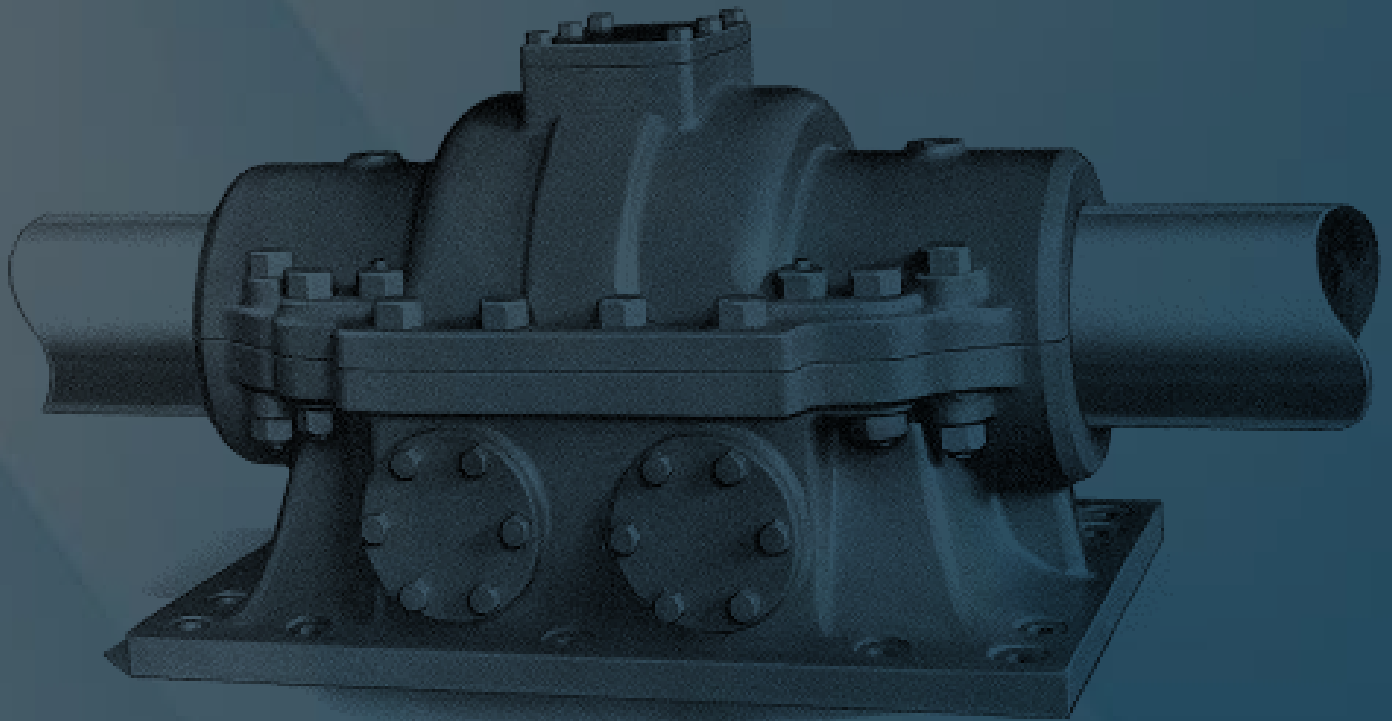
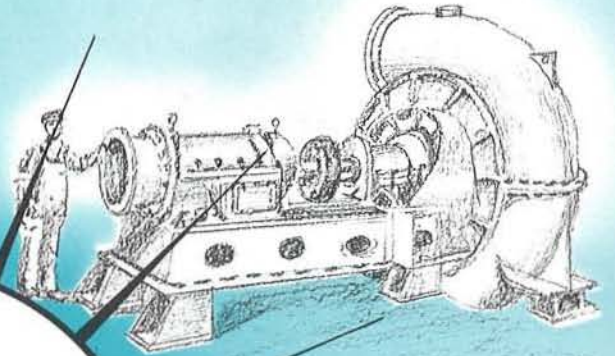
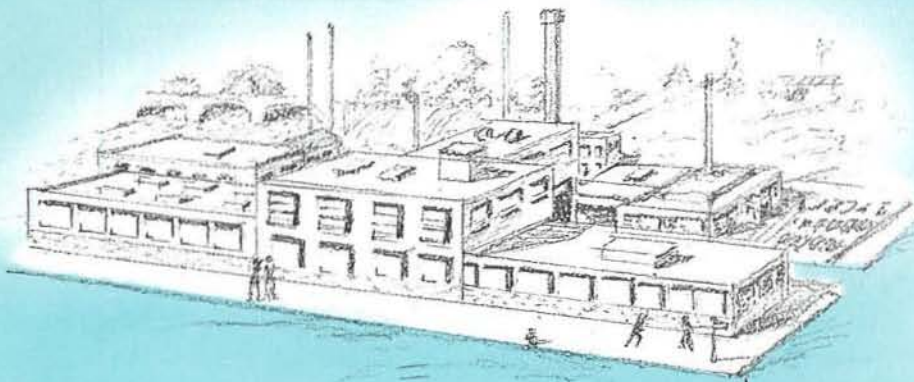

**KINGSBURY**

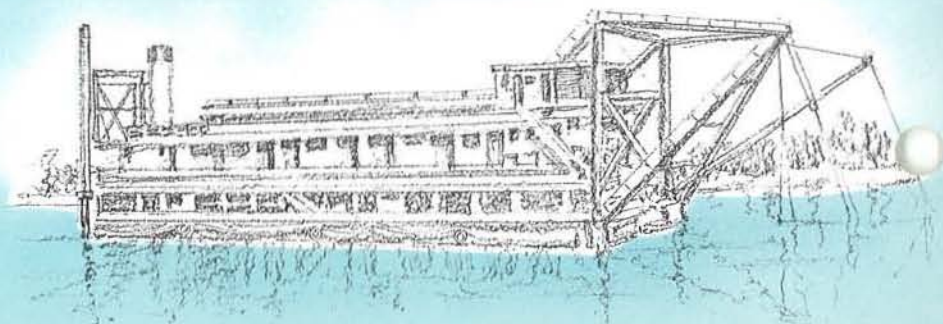
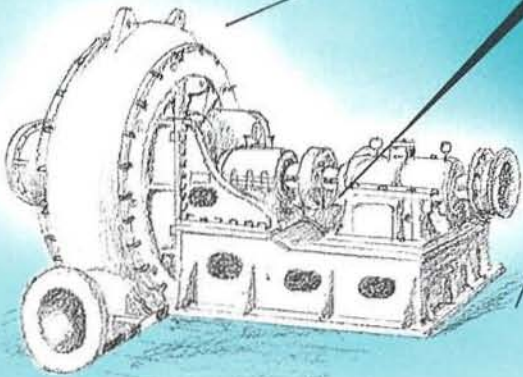

**KINGSBURY**  
**EQUALIZING BEARINGS**  
IN  
**Marine Type and Heavy Industrial**  
**Mountings**

DIMENSIONS  
and  
CAPACITIES

**CATALOG LH**



**KINGSBURY MACHINE WORKS, INC.**  
4324 TACKAWANNA STREET  
FRANKFORD, PHILADELPHIA 24, PENNA.

---

---

# CONTENTS

	PAGE
Foreword.....	5
Types of Bearings Included.....	6
Basic Kingsbury Elements.....	7
Pedestal Thrust and Journal Bearing Combinations	
Styles FF and FTF Bearings.....	8
Style LG Bearings.....	10
Style LD Line Shaft Bearings.....	11
Style L Journal Bearings.....	11
Lubrication.....	12
Cooling Requirements.....	12
Rated Thrust Capacities (Table I).....	13
Dimension Tables	
Styles FF and FTF Mountings.....	14
Style LG Mountings.....	16
Shaft Standards.....	17-20
Style LD Line Shaft Bearings.....	21
Style L Journal Bearings.....	22
Rated Capacities of Journal Bearings (Table II).....	23
Spare Parts.....	24
Data Needed for Ordering.....	24
Standard Guarantee.....	24

## FOREWORD

Thrust bearings for marine propulsion, when not enclosed in the machinery housing, are usually installed in pedestal-type mountings, provided by the bearing manufacturer, which are bolted directly to the ship's structure. Dredge pumps, likewise, usually have a pedestal-type thrust-and-journal bearing and an inboard journal bearing, mounted on the pump bedplate.

This catalog has been prepared to supply to the prospective user the data concerning thrust and journal bearings of this type, that will enable him to estimate closely the size and style of bearing required and to choose the unit most likely to fill his needs. It should be understood, however, that though we desire, by means of this booklet, to help establish a satisfactory preliminary design, it is nonetheless important that we be consulted and enabled to check the application before final plans and commitments are made. In addition, because of the possibility of minor changes, or special circumstances, the figures in the several dimension lists should be confirmed before basing space allocations on their use.

Explanation of the basic Kingsbury principle of wedge-shaped oil films, automatically self-renewed and preventing metallic contact and wear, will be found in other literature obtainable upon request.

---

## Types of Bearings Included

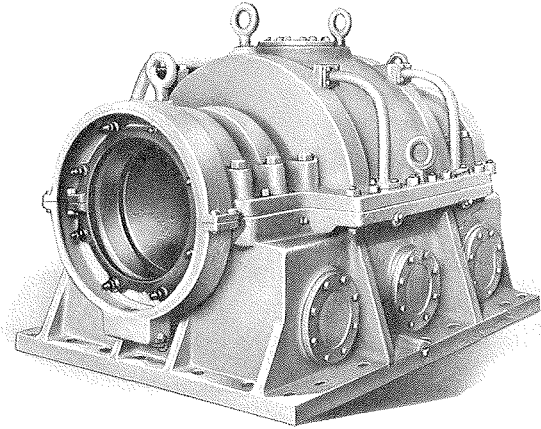

Figure 1  
Large Thrust and Journal Bearing for Marine  
propeller thrust application.

This catalog covers bearings of types FF and FTF and L, LD, and LG. These, with the exception of types L and LD, which are journal bearings, are thrust-and-journal bearings in which the thrust bearing is of the *equalizing* six-shoe type. There are available also two-shoe *adjustable* bearings which can be used for the same kinds of application under favorable operating conditions. These are not treated in this booklet but information regarding them will be furnished upon request.

The type L and LD journal bearings, being frequently used in conjunction with the thrust bearings named above, are described herein. Their descriptions will also be found in other literature because of their broad applicability.

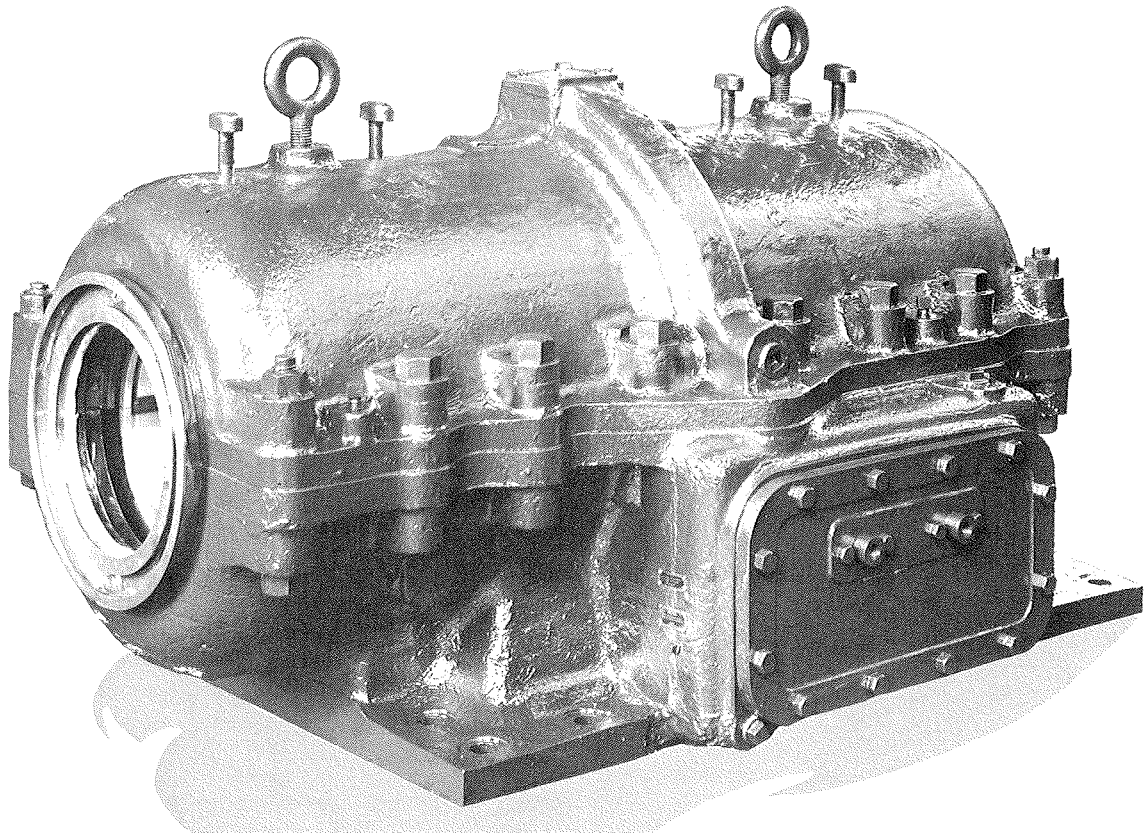

Figure 2  
Double six-shoe Thrust Bearing and Journal Bearing for Dredge Pump (Style LGL)

## Basic Kingsbury Elements

The basic elements of all Kingsbury Bearings are:

- (1) The stationary pivoted *Shoes*.
- (2) The *Thrust Collar* which rotates with the shaft and applies the load to the shoes.
- (3) The *Base Ring* including means of equalizing the shoe loads.
- (4) The *Housing* or mounting, which contains and supports the internal bearing elements.
- (5) The *Lubricating System* which continuously floods the collar and shoes with oil.
- (6) The *Cooling System* for removing the heat generated by the shearing of the oil film.

Every thrust bearing installation involves all these elements in one form or another. This catalog LH is, however, concerned only with the standard "equalizing" elements having six shoes and mounted in pedestal-type housings provided by the bearing manufacturer.

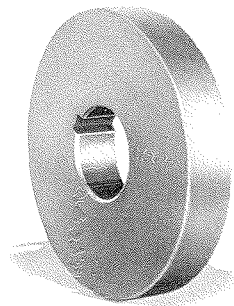

Figure 3  
Standard (removable) collar  
for bearings with horizontal  
shaft.

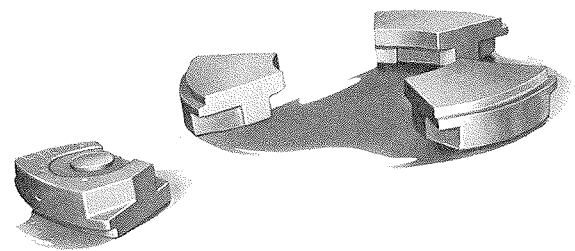

Figure 4  
Three pivoted shoes (a fourth is inverted to show the hardened steel  
"shoe support" set into its base).

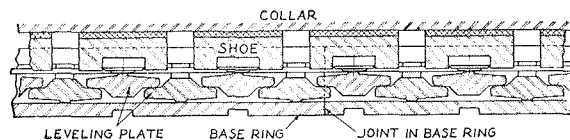

Figure 5: Developed section, showing how the leveling  
plates of six-shoe thrust bearings distribute the load  
equally among the shoes.

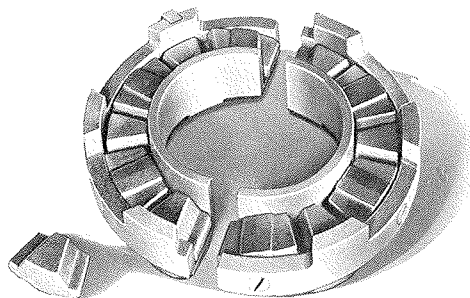

Figure 6  
Split base ring and leveling plates of small six-shoe  
bearing. A "lower" leveling plate is shown separately.

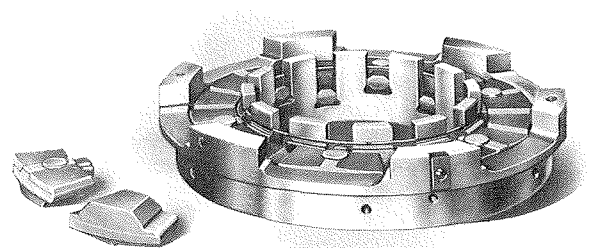
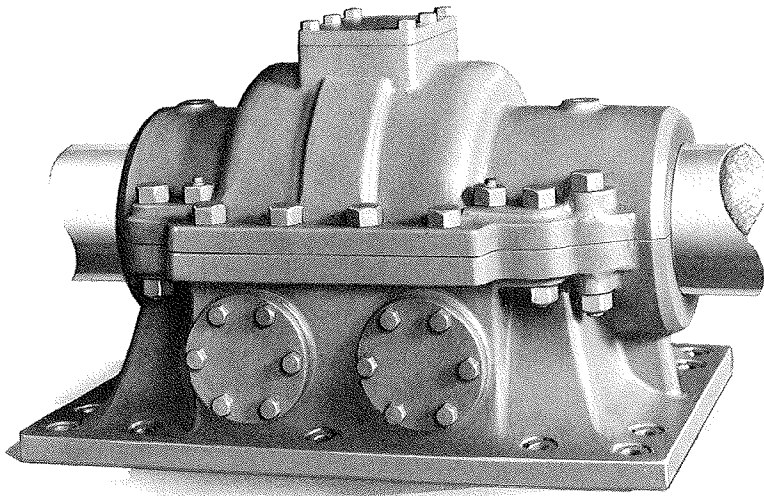

Figure 7  
Solid base ring with leveling plates in place. One upper and one  
lower leveling plate placed alongside for comparison.

---

# Styles FF and FTF Bearings

(Six Shoes)



## STYLE FF

Figure 8: Style FF Bearing.  
Combination of thrust and one journal bearing.

Styles FF and FTF afford the maximum thrust capacity for a given shaft size and collar diameter. They contain six bearing shoes of the form shown in Figure 4, page 7. The loads are equalized among the shoes by forged steel rocking levers or "leveling plates;" hence the thrust bearings in these mountings are known as "self-aligning and equalizing."

For ready assembly when the shaft is in place, the base rings are split as shown in Figure 6, and are inserted by first putting the bottom half of each ring over the shaft, then rotating it into place.

Sometimes the reverse thrust is much less than the principal or forward thrust. The two-shoe bearing element shown in Figure 13 may then be used in place of one of the six-shoe bearings. It has one-third the capacity of the latter. It may be used also to limit end play

Figure 9  
Vertical section and half end view of Style FF Bearing. Forced lubrication is generally used. Note the oil seal rings which permit the thrust cavity to be filled with oil without flooding the ends of the housing.

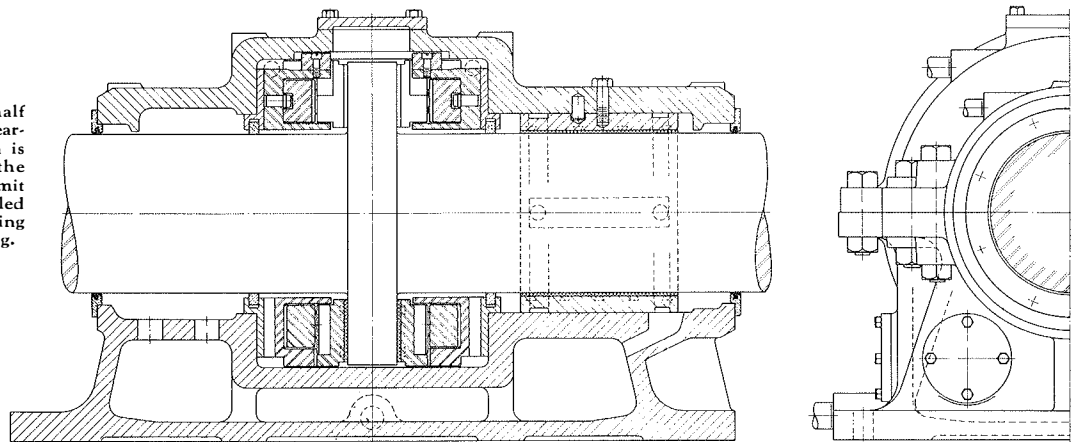

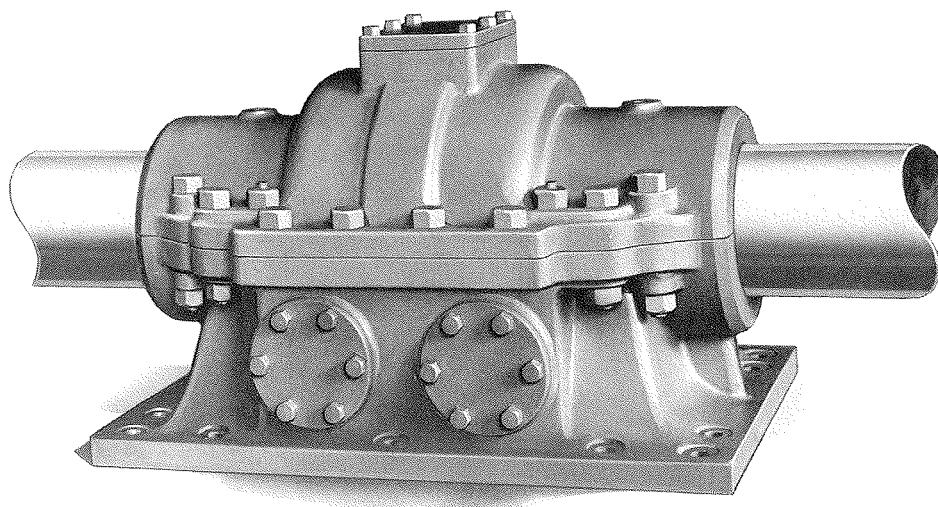

Figure 10  
Style FTF Bearing, a combination of a thrust and two journal bearings (one in each end).

### STYLE FTF

where the operating thrust is always in one direction. This two-shoe element is adjustable, but not self-equalizing.

The journal bearings in these thrust elements are fixed. Style FF mounting has one journal bearing; Style FTF mounting, with two journal bearings, has greater radial load capacity. This bearing arrangement is only required for special applications where conditions are such as to warrant its use.

Four shaft sizes are standard for each size of housing; the thrust capacity is somewhat less for the larger sizes in each housing.

It is assumed that Styles FF and FTF will be connected to a nearby circulating system supplying cooled oil.

Automatic lubrication could be provided for these mountings but, if that is desired, Style LG, which is designed to be self-oiling, should preferably be chosen instead.

The end closures are usually of simple design as in Figure 9, but when otherwise ordered may be of various forms suitable to the conditions.

Special housings can be furnished if necessary to fit the customer's construction.

Figure 11  
Large Style FTF Bearing, size 41. Forced lubrication is used, and the oil pipes are so arranged that the hinged cover may be raised without breaking the pipe connections.

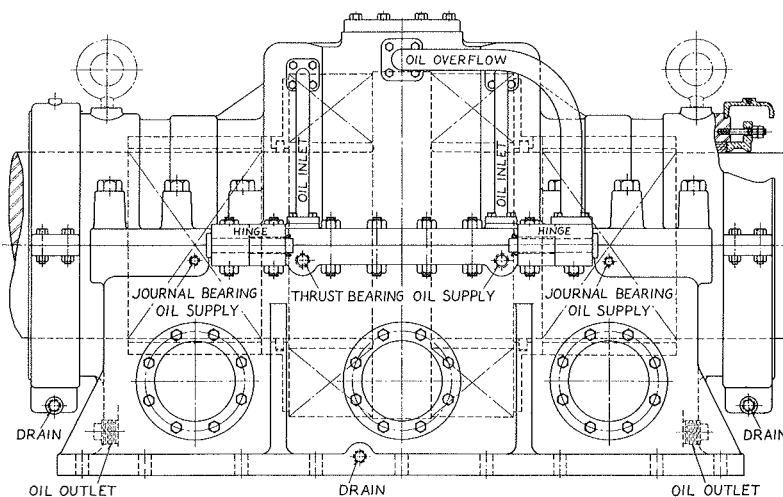

# Style LG Bearings

(Six Shoes)

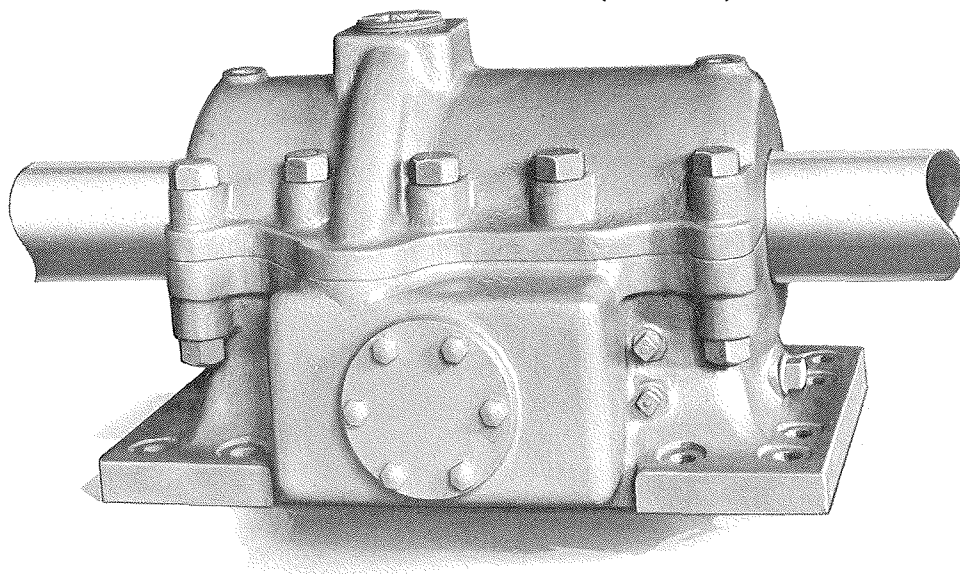

Figure 12  
Style LG Mounting as de-  
signed for the smaller sizes.

Style LG mounting contains a self-aligning journal bearing, together with an equalizing thrust bearing designed primarily for dredge pump service, and is built in sizes from 12 to 33 inches diameter of thrust collar. The thrust elements on one side of the thrust collar are of the six-shoe type used in Styles FF and FTF, including leveling plates and split base rings; on the other side two shoes are usually mounted.

The journal bearing, instead of being fixed as in all the styles previously described, is self-aligning. This feature allows the bearing to align

itself automatically with the shaft; and this is useful in case of unavoidable springing of a foundation. As the thrust shoes on the loaded side are self-aligning, they too can be considered protected against conditions of misalignment.

For dredge pump service a six-shoe thrust bearing is used on the load-carrying side, in connection with a two-shoe adjustable bearing on the side away from the main thrust, to limit end play. The loaded side must be clearly indicated in the order. Where the thrust load may be equal in either direction, the bearing elements should be alike on both sides of the thrust collar.

Figure 13  
Vertical lengthwise section  
and half end view of Style  
LG Bearing. Note oil circula-  
tor on thrust collar, by  
which the thrust cavity is  
filled with oil taken from  
the base; also the self-align-  
ing journal bearing.

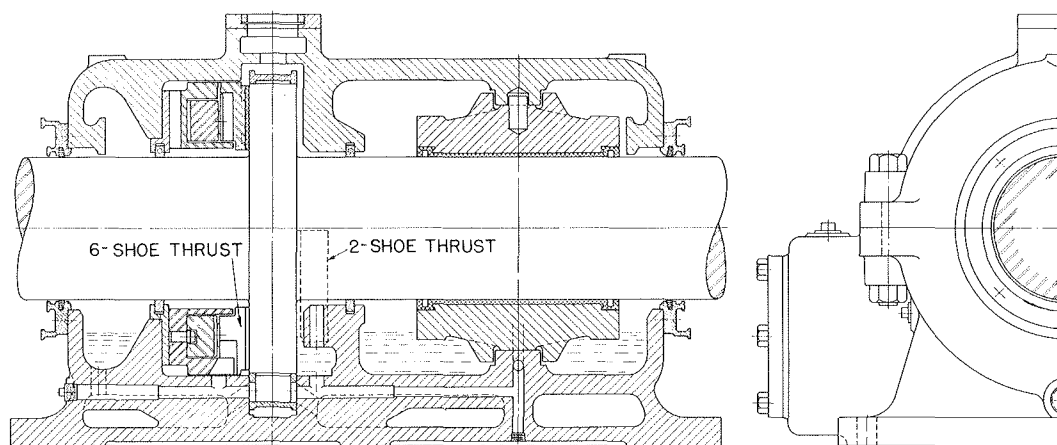

## Style LD Line Shaft Bearings

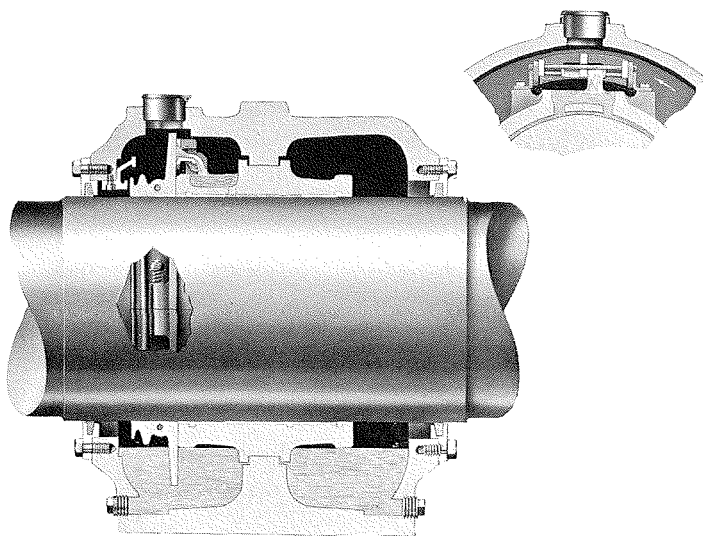

Figure 14  
Style LD Line Shaft Bearing. This bearing is  
disc-oiled and self-aligning.

Style LD Line Shaft Bearings are self-aligning and self-lubricating. Oil is picked up from the bath by a disc spring-clamped on the shaft, and is carried to a bronze wiper at the top. The wiper, bearing against one face of the disc, scrapes off oil and delivers it in a stream to a pocket in the top of the bearing shell. From the pocket oil runs down to feed the oil film. The shell has full bearing area in the lower half, and babbitted end strips in the upper half.

The usual end closures are felt rings as indicated in the illustrations.

Dimensions are given on page 21. Shaft sizes there listed are standard, but others can be accommodated by making the elements with special size bores.

## Style L Journal Bearings

For use on heavy-duty hydraulic dredges we furnish the self-aligning journal bearing shown in Figure 15. It has a removable shell, with full bearing area in each half arranged to receive a continual stream of oil under some pressure, feeding the oil films. Because of these features it carries successfully the whirling loads frequently set up in dredge pumps (as by a rock passing through the impeller).

Oil is pumped to the bearing from the Kingsbury self-lubricating thrust bearing, Style LG (six shoes, with oil circulator). Or oil may be delivered by a separate oil pump.

A suitable orifice should be installed in the oil supply pipe, to control oil flow.

Dimensions are given on page 22. Shaft sizes there listed are standard, but others can be accommodated when circumstances so require.

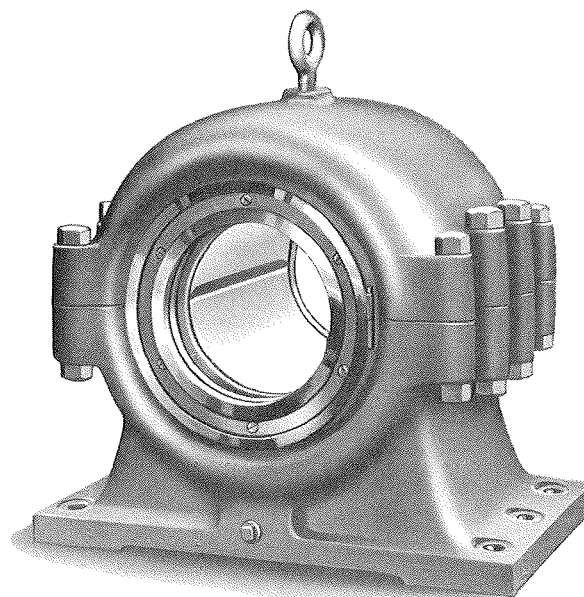

Figure 15  
Style L Journal Bearing. Used next to dredge pump impellers  
and for other heavy duty.

---

## Lubrication

Although the Kingsbury principle involves continual self-renewal of the oil films between shoes and collar, the thickness of those films (and hence the safety of the bearing) depends on the operating conditions. These conditions include load per square inch of shoe area (which can be greater with large shoes than with small ones), and viscosity of the oil at running temperature. Temperature depends on speed and on the cooling means.

Though the heating due to oil shear is small, it is a definite quantity which may be calculated. The cooling agent may be passed through an attached external cooler. Or the bearing may be tied into a general lubricating system with central cooling.

The "internal" resistance to flow of oil through the bearing assembly itself is slight. The piping and the oil passages in the bearing are designed to carry the required flow easily.

Three to five pounds per square inch oil pressure at the inlet is usually sufficient.

With oil cooling, the flow must be sufficient to carry off the heat generated by oil shear between shoes and collar. The operating instructions usually specify the viscosity and oil flow recommended.

## Cooling Requirements

The type FF and FTF bearings are usually arranged for forced lubrication from an external supply. Type LG bearings are fitted with a circulator for automatic lubrication, and an external cooler mounted on the housing.

In either case, since it is difficult to lay down general rules on this subject, we should be consulted in regard to the amount of cooling required for each specific application.

The circulator is a simple form of built-in "viscosity pump," operating on the periphery of

the thrust collar. This viscosity pump is entirely self-contained, automatic, and extremely simple, and it requires no attention. It develops enough pressure to circulate the oil through an external cooler located near the bearing mounting.

The thrust bearing may be located at the end of a shaft, using a separate thrust collar secured to the shaft by a nut. If the shaft does not extend through, the end of the housing may be closed by a cap. In such cases the thrust collar is furnished as one of the thrust elements.

Four, or in some cases three, shaft sizes are standard for each size of housing; the thrust capacity is somewhat less for the larger sizes in each housing. The largest just clears the standard base ring bore, which does not exceed 56 per cent of the mounting number.

End closures on the FF and FTF bearings and the LD line shaft bearings are usually of the "plain" type, consisting of a simple ring, in halves, grooved to hold a felt wiping ring and bolted to the ends of the housing base and cover. For the LG and LGL bearings a somewhat more elaborate closure of the same general type is provided, as shown in Figure 13, and also for the type L journal bearings.

In dredge pump applications, in which there is danger of contamination of the lubricant by water flowing along the shaft, a water thrower is provided on the shaft, at the end of the bearing adjacent to the pump. A lip on the thrower rim overhangs the outer edge of the closure. Therefore it is important to note that it is necessary to remove the thrower before the bearing housing cover can be lifted.

A special form of the LG mounting is Style LGL. This has two similar, self-aligning bearings, one on each side of the thrust bearing, but their bores may be different. Base dimensions are the same as in Style LG. The second journal bearing extends beyond one end of the base, a convenient construction for some uses. See Figure 2, page 6.

Other special housings can be furnished if necessary to fit the customer's requirements.

## Rated Thrust Capacities (in Pounds)

Styles FF, FTF and LG

Adequate Cooling is Assumed

SIX-SHOE BEARINGS

TABLE I

Bearing Size	Shaft Diameter	Revolutions per Minute					
		100	150	200	300	500	700
12	5.250	17500	18500	19500	21000	23300	24200
	6.000	13300	14000	14800	16000	17700	18400
13½	5.625	23500	25000	26500	28000	31000	32500
	7.000	17900	19000	20200	21300	23600	24700
15	6.500	30500	32000	34000	36500	40000	42000
	7.500	23200	24300	25800	27800	30400	31900
17	7.500	41500	44000	46500	49500	54000	57000
	8.500	31500	33400	35400	37600	41000	43300
19	8.500	54000	58000	61000	66000	71000	75500
	9.625	41000	44100	46400	50000	54000	57400
21	9.000	69500	74000	79000	84000	91000	96000
	10.875	52800	56200	60000	63800	69200	73000
23	10.250	86500	92500	97000	105000	113000	119000
	12.125	65700	70300	73700	80000	86000	90400
25	10.875	107000	115000	120000	130000	140000	148000
	12.875	81300	87500	91200	99000	106000	113000
27	12.125	128000	137000	143000	155000	168000	176000
	13.625	97400	104000	109000	118000	128000	134000
29	12.875	152000	163000	170000	185000	200000	211000
	14.375	115500	124000	129000	140000	152000	160000
31	13.625	179000	192000	200000	217000	234000	248000
	15.875	136000	146000	152000	165000	178000	188000
33	14.375	209000	224000	234000	253000	273000	288000
	16.750	159000	170000	176000	192000	208000	219000
37	16.750	275000	295000	310000	335000	360000	.....
	18.500	209000	234000	236000	255000	274000	.....
41	18.500	355000	380000	395000	430000	460000	.....
	20.250	270000	289000	300000	327000	350000	.....
45	20.250	440000	470000	495000	535000	575000	.....
	22.250	335000	358000	376000	407000	437000	.....

There are four standard shaft sizes for most bearing sizes: see pages 14 to 16. The larger sizes reduce the shoe area and hence the thrust capac-

ity. For the intermediate standard shaft sizes, the thrust capacities may be estimated with sufficient closeness.

# Styles FF and FTF Mountings

(Six Shoes)

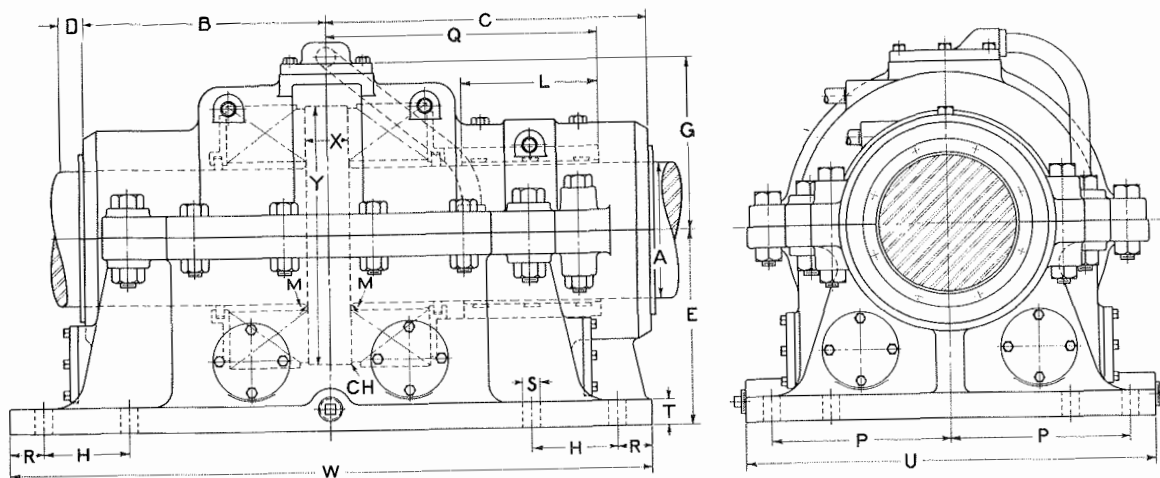

STYLE FF

For drawing of Style FTF see next page.

Caution: Before actual construction these dimensions should be confirmed by a certified print.

ALL DIMENSIONS ARE IN INCHES

Bearing Numbers . . . . .	FF-12 FTF-12	FF-13½ FTF-13½	FF-15 FTF-15	FF-17 FTF-17	FF-19 FTF-19	FF-21 FTF-21	FF-23 FTF-23	FF-25 FTF-25
Shaft A-1 . . . . .	5.250	5.625	6.500	7.500	8.500	9.000	10.250	10.875
Shaft A-2 . . . . .	5.625	6.000	7.000	8.000	9.000	9.625	10.875	11.500
Shaft A-3 . . . . .	6.000	6.500	7.500	8.500	9.625	10.250	11.500	12.125
Shaft A-4 . . . . .	....	7.000	....	....	....	10.875	12.125	12.875
WEIGHTS (Lbs. Net)								
FF Bearing, complete . . . . .	700	950	1250	1750	2400	3100	4000	5000
FTF Bearing, complete . . . . .	750	1000	1335	1875	2560	3330	4300	5385
6 Spare Shoes . . . . .	26	35	45	62	91	122	165	227
Spare Half Bearing Shell . . . . .	18	22	32	45	65	82	110	135
B . . . . .	12½	13	14¼	16⅝	18	19½	20¾	22¾
C . . . . .	15½	17¼	18¾	21¼	22½	25	27	29
D (min. space to repack) . . . . .	2¼	2½	2½	2½	2½	3	3	3
E . . . . .	9⅞	10¾	12	13⅜	14¾	15½	16¾	18
G . . . . .	8¼	9¼	10¼	11¾	13½	14¾	16	17½
H . . . . .	4⅞	5	5	5⅞	5⅞	6¼	6¼	....
L . . . . .	Length of Journal equal to diameter of shaft							
M (Fillet Rad.) . . . . .	⅛	⅛	⅝	⅝	⅜	⅜	¼	¼
P . . . . .	8⅞	9⅞	10½	11⅜	13	14⅞	15⅞	16⅞
Q . . . . .	13	14⅞	15⅞	18	19¼	20¾	22¾	24¼
R . . . . .	1¾	2	2	2¼	2¼	2½	2½	2¾
S (Bolt Dia.) . . . . .	⅞	1	1	1⅞	1⅞	1¼	1¼	1½
T . . . . .	1¼	1½	1½	1¾	1¾	1⅞	1⅞	2⅞
U . . . . .	19¾	22¼	24	27	29¼	32	34½	37½
W . . . . .	32	34½	37½	42½	46	50	54	58
X . . . . .	2.000	2.250	2.500	2.875	3.250	3.625	3.875	4.250
Y . . . . .	12⅜	13⅜	15⅜	17¼	19¼	21¼	23¼	25¼
CH (Chamfer) . . . . .	⅛	⅛	⅛	⅛	⅛	⅛	⅛	⅛

## Styles FF and FTF Mountings

(Six Shoes)

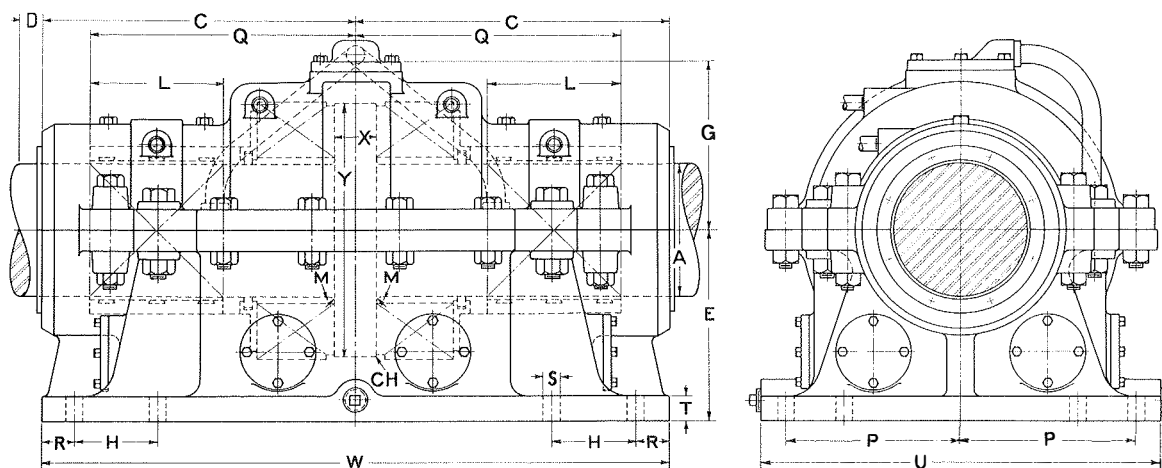

STYLE FTF

For drawing of Style FF see preceding page.

Caution: Before actual construction, these dimensions should be confirmed by a certified print.

ALL DIMENSIONS ARE IN INCHES

Bearing Numbers . . . . .	FF-27 FTF-27	FF-29 FTF-29	FF-31 FTF-31	FF-33 FTF-33	FF-37 FTF-37	FF-41 FTF-41	FF-45 FTF-45
Shaft A-1 . . . . .	12.125	12.875	13.625	14.375	16.750	18.500	20.250
Shaft A-2 . . . . .	12.875	13.625	14.375	15.125	17.625	19.375	21.250
Shaft A-3 . . . . .	13.625	14.375	15.125	15.875	18.500	20.250	22.250
Shaft A-4 . . . . .	....	....	15.875	16.750	....	....	....
<b>WEIGHTS</b> (Lbs. Net)							
FF Bearing, complete . . . . .	6200	7500	9000	11000	15000	20000	25800
FTF Bearing, complete . . . . .	6670	8075	9700	11900	16200	21500	27800
6 Spare Shoes . . . . .	242	305	388	550	666	818	1150
Spare Half Bearing Shell . . . . .	200	225	250	300	420	500	670
B . . . . .	24 $\frac{3}{4}$	26 $\frac{1}{2}$	28	30	34 $\frac{1}{2}$	38 $\frac{1}{2}$	42
C . . . . .	31 $\frac{1}{4}$	33 $\frac{1}{2}$	35	37	41 $\frac{1}{2}$	45 $\frac{1}{2}$	49
D (min. space to repack) . . . . .	3	3	3 $\frac{1}{4}$	3 $\frac{1}{4}$	3 $\frac{1}{4}$	3 $\frac{1}{4}$	3 $\frac{1}{4}$
E . . . . .	19 $\frac{3}{8}$	20 $\frac{1}{2}$	22	23 $\frac{1}{4}$	26	28 $\frac{1}{2}$	31
G . . . . .	19	20 $\frac{1}{2}$	21 $\frac{3}{4}$	23	26 $\frac{1}{2}$	28	31 $\frac{1}{2}$
H . . . . .	....	....	....	....	....	....	....
L . . . . .	Length of Journal equal to diameter of shaft						
M (Fillet Rad.) . . . . .	$\frac{5}{16}$	$\frac{3}{8}$	$\frac{3}{8}$	$\frac{7}{16}$	$\frac{1}{2}$	$\frac{9}{16}$	$\frac{5}{8}$
P . . . . .	17 $\frac{7}{8}$	19 $\frac{3}{8}$	20 $\frac{5}{8}$	22	25	27 $\frac{1}{2}$	30
Q . . . . .	26 $\frac{3}{4}$	28 $\frac{1}{4}$	29 $\frac{3}{4}$	31 $\frac{1}{2}$	35 $\frac{3}{4}$	39	42 $\frac{1}{2}$
R . . . . .	2 $\frac{3}{4}$	3	3	3	3	3	3
S (Bolt Dia.) . . . . .	1 $\frac{1}{2}$	1 $\frac{1}{2}$	1 $\frac{1}{2}$	1 $\frac{1}{2}$	1 $\frac{1}{2}$	1 $\frac{1}{2}$	1 $\frac{1}{2}$
T . . . . .	2 $\frac{1}{8}$	2 $\frac{1}{4}$	2 $\frac{1}{4}$	2 $\frac{3}{8}$	2 $\frac{1}{2}$	2 $\frac{5}{8}$	2 $\frac{3}{4}$
U . . . . .	40	43	45 $\frac{1}{2}$	48 $\frac{1}{2}$	54 $\frac{1}{2}$	60	65 $\frac{1}{2}$
W . . . . .	62 $\frac{1}{2}$	67	70	74	83	91	98
X . . . . .	4.625	5.000	5.250	5.625	6.375	7.000	7.625
Y . . . . .	27 $\frac{1}{4}$	29 $\frac{3}{8}$	31 $\frac{3}{8}$	33 $\frac{3}{8}$	37 $\frac{1}{2}$	41 $\frac{1}{2}$	45 $\frac{1}{2}$
CH (Chamfer) . . . . .	$\frac{1}{32}$	$\frac{1}{16}$	$\frac{1}{16}$	$\frac{1}{16}$	$\frac{1}{16}$	$\frac{1}{16}$	$\frac{1}{16}$

# Style LG Mountings

(Six Shoes)

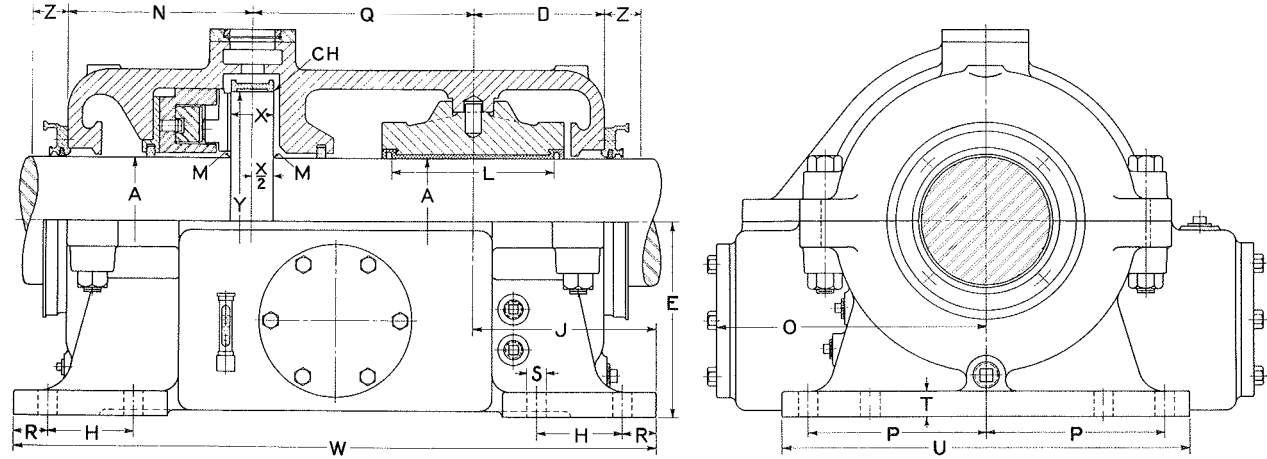

Caution: Before actual construction these dimensions should be confirmed by a certified print.

ALL DIMENSIONS ARE IN INCHES

Bearing Numbers . . .	LG-12	LG-13½	LG-15	LG-17	LG-19	LG-21	LG-23	LG-25	LG-27	LG-29	LG-31	LG-33
Shaft A-1 . . . . .	5.250	5.625	6.500	7.500	8.500	9.000	10.250	10.875	12.125	12.875	13.625	14.375
Shaft A-2 . . . . .	5.625	6.000	7.000	8.000	9.000	9.625	10.875	11.500	12.875	13.625	14.375	15.125
Shaft A-3 . . . . .	6.000	6.500	7.500	8.500	9.625	10.250	11.500	12.125	13.625	14.375	15.125	15.875
Shaft A-4 . . . . .	6.500	7.000	8.000	9.000	10.250	10.875	12.125	12.875	14.375	15.125	15.875	16.750
<b>WEIGHTS</b> (Lbs. Net)												
LG Bearing, complete . . .	1000	1350	1770	2450	3300	4300	5500	6800	8300	10000	12000	14200
6 Spare Shoes . . . . .	26	35	45	62	91	122	165	227	242	305	388	550
Spare Bearing Shell . . . .	110	154	210	300	400	550	700	880	1080	1320	1600	1860
D . . . . .	6 <sup>5</sup> / <sub>16</sub>	7 <sup>5</sup> / <sub>16</sub>	7 <sup>7</sup> / <sub>8</sub>	8 <sup>3</sup> / <sub>4</sub>	9 <sup>1</sup> / <sub>2</sub>	10 <sup>1</sup> / <sub>8</sub>	11 <sup>1</sup> / <sub>4</sub>	12	13 <sup>3</sup> / <sub>8</sub>	14	14 <sup>3</sup> / <sub>4</sub>	16
E . . . . .	9 <sup>7</sup> / <sub>8</sub>	10 <sup>3</sup> / <sub>4</sub>	12	13 <sup>3</sup> / <sub>8</sub>	14 <sup>3</sup> / <sub>4</sub>	15 <sup>1</sup> / <sub>2</sub>	16 <sup>3</sup> / <sub>4</sub>	18	19 <sup>3</sup> / <sub>8</sub>	20 <sup>1</sup> / <sub>2</sub>	22	23 <sup>1</sup> / <sub>4</sub>
H . . . . .	4 <sup>3</sup> / <sub>8</sub>	5	5	5 <sup>5</sup> / <sub>8</sub>	5 <sup>5</sup> / <sub>8</sub>	6 <sup>1</sup> / <sub>4</sub>	6 <sup>1</sup> / <sub>4</sub>	6 <sup>7</sup> / <sub>8</sub>	6 <sup>7</sup> / <sub>8</sub>	7 <sup>1</sup> / <sub>2</sub>	7 <sup>1</sup> / <sub>2</sub>	7 <sup>1</sup> / <sub>2</sub>
J . . . . .	9 <sup>5</sup> / <sub>16</sub>	10 <sup>7</sup> / <sub>16</sub>	11	12 <sup>1</sup> / <sub>4</sub>	13 <sup>1</sup> / <sub>2</sub>	14 <sup>7</sup> / <sub>16</sub>	15 <sup>11</sup> / <sub>16</sub>	16 <sup>13</sup> / <sub>16</sub>	18 <sup>3</sup> / <sub>16</sub>	19 <sup>1</sup> / <sub>4</sub>	19 <sup>15</sup> / <sub>16</sub>	21 <sup>3</sup> / <sub>16</sub>
L . . . . .	7 <sup>3</sup> / <sub>4</sub>	8 <sup>1</sup> / <sub>2</sub>	9 <sup>1</sup> / <sub>2</sub>	10 <sup>3</sup> / <sub>4</sub>	12 <sup>1</sup> / <sub>4</sub>	13	14 <sup>1</sup> / <sub>2</sub>	15 <sup>1</sup> / <sub>2</sub>	17 <sup>1</sup> / <sub>4</sub>	18 <sup>1</sup> / <sub>8</sub>	19	20
M (Fillet Rad.) . . . . .	1 <sup>1</sup> / <sub>8</sub>	1 <sup>1</sup> / <sub>8</sub>	5 <sup>5</sup> / <sub>32</sub>	5 <sup>5</sup> / <sub>32</sub>	3 <sup>3</sup> / <sub>16</sub>	3 <sup>3</sup> / <sub>16</sub>	1 <sup>1</sup> / <sub>4</sub>	1 <sup>1</sup> / <sub>4</sub>	5 <sup>1</sup> / <sub>16</sub>	3 <sup>3</sup> / <sub>8</sub>	3 <sup>3</sup> / <sub>8</sub>	1 <sup>1</sup> / <sub>16</sub>
N . . . . .	9 <sup>1</sup> / <sub>2</sub>	10 <sup>1</sup> / <sub>2</sub>	11 <sup>3</sup> / <sub>8</sub>	12 <sup>3</sup> / <sub>4</sub>	12 <sup>3</sup> / <sub>4</sub>	13 <sup>5</sup> / <sub>8</sub>	14 <sup>5</sup> / <sub>8</sub>	15 <sup>3</sup> / <sub>4</sub>	17	18	18 <sup>7</sup> / <sub>8</sub>	19 <sup>7</sup> / <sub>8</sub>
O (Approx.) . . . . .	13 <sup>1</sup> / <sub>4</sub>	14 <sup>1</sup> / <sub>8</sub>	15 <sup>3</sup> / <sub>4</sub>	17 <sup>1</sup> / <sub>8</sub>	19	20	21 <sup>1</sup> / <sub>4</sub>	22 <sup>1</sup> / <sub>2</sub>	23 <sup>3</sup> / <sub>4</sub>	25	26 <sup>1</sup> / <sub>2</sub>	28
P . . . . .	8 <sup>5</sup> / <sub>16</sub>	9 <sup>5</sup> / <sub>8</sub>	10 <sup>1</sup> / <sub>2</sub>	11 <sup>13</sup> / <sub>16</sub>	13	14 <sup>1</sup> / <sub>8</sub>	15 <sup>3</sup> / <sub>8</sub>	16 <sup>5</sup> / <sub>8</sub>	17 <sup>7</sup> / <sub>8</sub>	19 <sup>3</sup> / <sub>8</sub>	20 <sup>5</sup> / <sub>8</sub>	22
Q . . . . .	11 <sup>11</sup> / <sub>16</sub>	12 <sup>11</sup> / <sub>16</sub>	13 <sup>13</sup> / <sub>16</sub>	15 <sup>7</sup> / <sub>16</sub>	15 <sup>3</sup> / <sub>4</sub>	16 <sup>5</sup> / <sub>8</sub>	18 <sup>1</sup> / <sub>4</sub>	19 <sup>5</sup> / <sub>8</sub>	21 <sup>1</sup> / <sub>4</sub>	22 <sup>3</sup> / <sub>4</sub>	24	25 <sup>1</sup> / <sub>4</sub>
R . . . . .	1 <sup>3</sup> / <sub>4</sub>	2	2	2 <sup>1</sup> / <sub>4</sub>	2 <sup>1</sup> / <sub>4</sub>	2 <sup>1</sup> / <sub>2</sub>	2 <sup>1</sup> / <sub>2</sub>	2 <sup>3</sup> / <sub>4</sub>	2 <sup>3</sup> / <sub>4</sub>	3	3	3
S (Bolt Dia.) . . . . .	7 <sup>1</sup> / <sub>8</sub>	1	1	1 <sup>1</sup> / <sub>8</sub>	1 <sup>1</sup> / <sub>8</sub>	1 <sup>1</sup> / <sub>4</sub>	1 <sup>1</sup> / <sub>4</sub>	1 <sup>1</sup> / <sub>2</sub>	1 <sup>1</sup> / <sub>2</sub>	1 <sup>1</sup> / <sub>2</sub>	1 <sup>1</sup> / <sub>2</sub>	1 <sup>1</sup> / <sub>2</sub>
T . . . . .	1 <sup>1</sup> / <sub>4</sub>	1 <sup>1</sup> / <sub>2</sub>	1 <sup>1</sup> / <sub>2</sub>	1 <sup>3</sup> / <sub>4</sub>	1 <sup>3</sup> / <sub>4</sub>	1 <sup>7</sup> / <sub>8</sub>	1 <sup>7</sup> / <sub>8</sub>	2 <sup>1</sup> / <sub>8</sub>	2 <sup>1</sup> / <sub>8</sub>	2 <sup>1</sup> / <sub>4</sub>	2 <sup>1</sup> / <sub>4</sub>	2 <sup>3</sup> / <sub>8</sub>
U . . . . .	19 <sup>3</sup> / <sub>4</sub>	22 <sup>1</sup> / <sub>4</sub>	24	27	29 <sup>1</sup> / <sub>4</sub>	32	34 <sup>1</sup> / <sub>2</sub>	37 <sup>1</sup> / <sub>2</sub>	40	43	45 <sup>1</sup> / <sub>2</sub>	48 <sup>1</sup> / <sub>2</sub>
W . . . . .	33	36 <sup>3</sup> / <sub>4</sub>	39 <sup>1</sup> / <sub>2</sub>	44	46	49	53	57	61 <sup>1</sup> / <sub>4</sub>	65 <sup>1</sup> / <sub>4</sub>	68	71 <sup>1</sup> / <sub>2</sub>
X . . . . .	2.000	2.250	2.500	2.875	3.250	3.625	3.875	4.250	4.625	5.000	5.250	5.625
Y . . . . .	12.188	13.688	15.188	17.250	19.250	21.250	23.250	25.250	27.250	29.375	31.375	33.375
Z (min. space to repack)	3	3 <sup>1</sup> / <sub>4</sub>	3 <sup>1</sup> / <sub>4</sub>	3 <sup>1</sup> / <sub>4</sub>	3 <sup>1</sup> / <sub>4</sub>	4	4	4	4	4	4 <sup>1</sup> / <sub>2</sub>	4 <sup>1</sup> / <sub>2</sub>
CH (Chamfer) . . . . .	1 <sup>1</sup> / <sub>64</sub>	1 <sup>1</sup> / <sub>32</sub>	1 <sup>1</sup> / <sub>32</sub>	1 <sup>1</sup> / <sub>32</sub>	1 <sup>1</sup> / <sub>32</sub>	1 <sup>1</sup> / <sub>32</sub>	1 <sup>1</sup> / <sub>32</sub>	1 <sup>1</sup> / <sub>32</sub>	1 <sup>1</sup> / <sub>32</sub>	1 <sup>1</sup> / <sub>16</sub>	1 <sup>1</sup> / <sub>16</sub>	1 <sup>1</sup> / <sub>16</sub>
Oil Capacity . . . . .	6 gal.	8 gal.	11 gal.	15 gal.	20 gal.	26 gal.	33 gal.	41 gal.	50 gal.	60 gal.	75 gal.	90 gal.

## Thrust Shafts

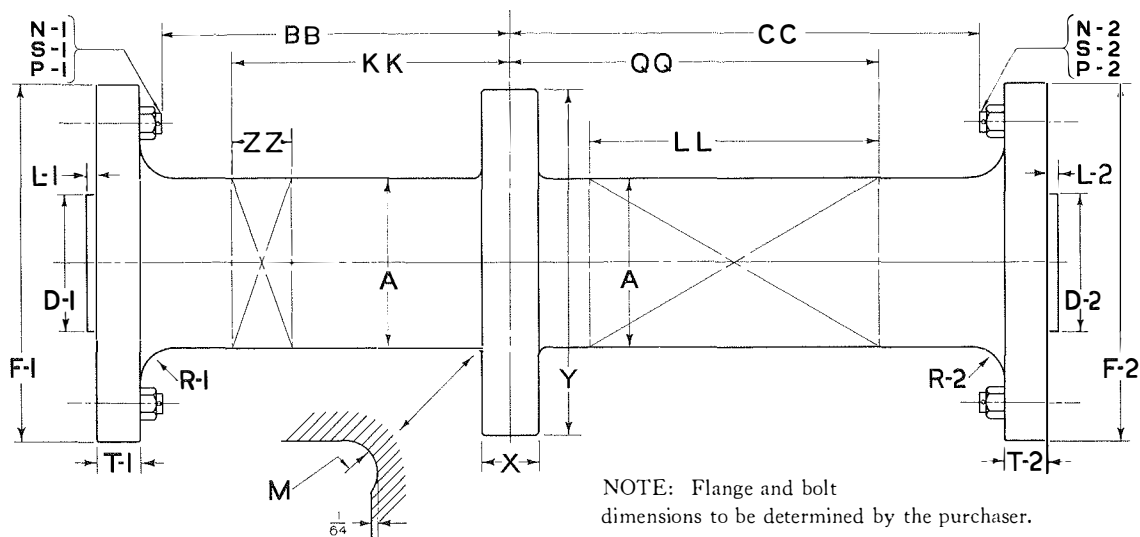

NOTE: Flange and bolt dimensions to be determined by the purchaser.

### Dimensions

The sketch above is dimensioned only with letters, and is to be used as a reference in correspondence.

Shaft size is determined from power, revolutions and type of drive; also by the need of avoiding torsional vibrations. The exact diameter A should agree with one alternative in dimension table for the style of bearing chosen (FF, FTF or LG).

Collar size is governed by the shaft diameter and the thrust load. Thickness X and diameter Y are given, for each nominal bearing size, in the dimension tables, and should be strictly followed.

Length dimensions KK, LL and QQ are governed by the dimensions of the housing selected and its built-in journal bearing. Dimensions BB and CC are determined by the customer; but of course they must be sufficient to keep the coupling bolt heads clear of the limit lines for removing the end closures. These limit lines are shown by dimensions D and Z in the dimension tables.

Coupling flange dimensions are chosen in accordance with accepted standards, or may be made to match special mating flanges. The diameter is usually not less than  $1\frac{3}{4}$  to 2 times the shaft diameter. The thickness is usually from  $\frac{1}{5}$  to  $\frac{1}{4}$  of the shaft diameter. Sometimes condi-

tions call for removable couplings, either rigid or flexible types.

Collar, journal and flanges must be exactly square and true. The collar faces, and the shaft in way of journal bearing and end closures, should be finished by lapping or polishing.

Bearings for propulsion may be placed with the journal either forward or aft of the collar. Thrust bearings on dredges are placed with the collar nearer the pump, the journal bearing nearer the drive.

### Machining

Turn both collar faces and journal at one setting in the lathe. Collar thickness must be the same all around, and collar faces must be flat as tested by straightedge held in radial position. Journal must be turned truly cylindrical throughout.

Chamfer collar rim slightly and turn smooth.

### Final Finishing

Collar faces must be finished very smooth. Tool marks must be removed by lapping, by smooth grinding or by light polishing in lathe, using a fine flat oil stone with kerosene, holding stone in hand and moving back and forth slowly while collar revolves.

Journal surface must be made smooth by lapping, by smooth grinding, or by hand stoning while revolving in lathe.

# Shaft Dimensions for FF and FTF Bearings

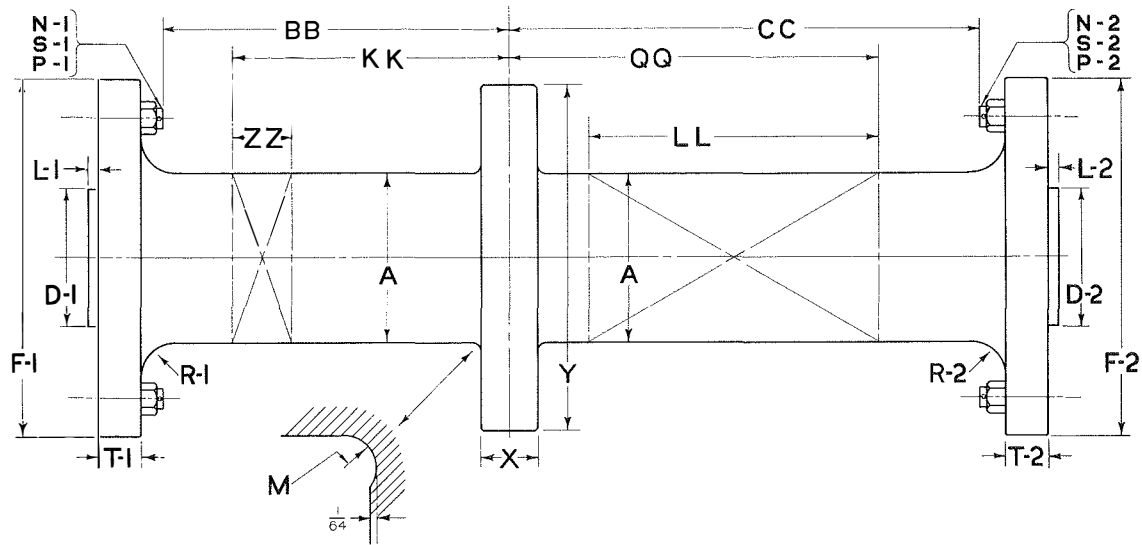

**Caution:** Before actual construction these dimensions should be confirmed by a certified print.

NOTE: Flange and bolt dimensions to be determined by the purchaser.

ALL DIMENSIONS ARE IN INCHES

Bearing Numbers	12	13½	15	17	19	21	23	
A ± .001 . . . . . <span style="font-size: 2em; vertical-align: middle;">}</span>	FF	5.250	5.625	6.500	7.500	8.500	9.000	10.250
	or	5.625	6.000	7.000	8.000	9.000	9.625	10.875
	FTF	6.000	6.500	7.500	8.500	9.625	10.250	11.500
		—	7.000	—	—	—	10.875	12.125
BB Min. Approx. . . . .	FF	16	17¼	18½	20¾	22¼	24¾	26
CC Min. Approx. . . . .	FF	19½	21½	23	25½	26¾	30¼	32¼
	FTF	19½	21½	23	25½	26¾	30¼	32¼
KK . . . . .	FF	14¾	15½	16¾	19	20½	22½	23¾
LL (Lap or Polish) . . . .	FF	12¼	13¾	14¾	16	17¼	19½	21
	FTF	12¼	13¾	14¾	16	17¼	19½	21
M . . . . .	FF	⅛	⅛	⅜	⅜	⅜	⅜	¼
	FTF	⅛	⅛	⅜	⅜	⅜	⅜	¼
QQ . . . . .	FF	17¾	19¾	21¼	23¾	25	28	30
	FTF	17¾	19¾	21¼	23¾	25	28	30
X . . . . .	FF	2.000	2.250	2.500	2.875	3.250	3.625	3.875
	FTF	2.000	2.250	2.500	2.875	3.250	3.625	3.875
Y . . . . .	FF	12⅜	13⅜	15⅜	17¼	19¼	21¼	23¼
	FTF	12⅜	13⅜	15⅜	17¼	19¼	21¼	23¼
ZZ (Lap or Polish) . . . .	FF	4½	5	5	5	5	6	6
Chamfer Collar . . . . .	FF	⅛	⅜	⅜	⅜	⅜	⅜	⅜
	FTF	⅛	⅜	⅜	⅜	⅜	⅜	⅜

## Shaft Dimensions for FF and FTF Bearings

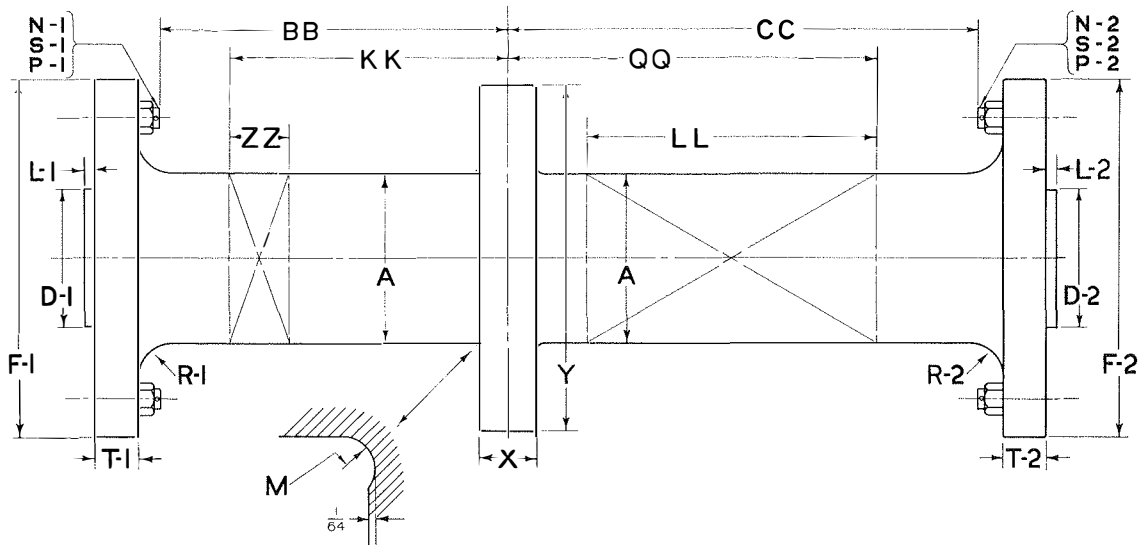

NOTE: Flange and bolt dimensions to be determined by the purchaser.

Caution: Before actual construction these dimensions should be confirmed by a certified print.

ALL DIMENSIONS ARE IN INCHES

Bearing Numbers	25	27	29	31	33	37	41	45	
A ± .001 . . . . .	$\left. \begin{array}{l} \text{FF} \\ \text{or} \\ \text{FTF} \end{array} \right\}$	10.875	12.125	12.875	13.625	14.375	16.750	18.500	20.250
		11.500	12.875	13.625	14.375	15.125	17.625	19.375	21.250
		12.125	13.625	14.375	15.125	15.875	18.500	20.250	22.250
		12.875	....	....	15.875	16.750	....	....	....
BB Min. Approx. . . .	FF	28	30	31 $\frac{3}{4}$	34	36	40 $\frac{1}{2}$	44 $\frac{1}{2}$	48
CC Min. Approx. . . .	FF FTF	34 $\frac{1}{4}$	36 $\frac{1}{2}$	38 $\frac{3}{4}$	41	43	47 $\frac{1}{2}$	51 $\frac{1}{2}$	55
KK . . . . .	FF	25 $\frac{3}{4}$	27 $\frac{3}{4}$	29 $\frac{1}{2}$	31 $\frac{1}{4}$	33 $\frac{1}{4}$	37 $\frac{3}{4}$	41 $\frac{3}{4}$	45 $\frac{1}{4}$
LL (Lap or Polish) . . .	FF FTF	22 $\frac{1}{4}$	23 $\frac{1}{4}$	25 $\frac{1}{2}$	26 $\frac{1}{2}$	27 $\frac{1}{2}$	29 $\frac{1}{2}$	32	34
M . . . . .	FF FTF	$\frac{1}{4}$	$\frac{5}{16}$	$\frac{3}{8}$	$\frac{3}{8}$	$\frac{7}{16}$	$\frac{1}{2}$	$\frac{5}{16}$	$\frac{5}{8}$
QQ . . . . .	FF FTF	32	34 $\frac{1}{4}$	36 $\frac{1}{2}$	38 $\frac{1}{4}$	40 $\frac{1}{4}$	44 $\frac{3}{4}$	48 $\frac{3}{4}$	52 $\frac{1}{4}$
X . . . . .	FF FTF	4.250	4.625	5.000	5.250	5.625	6.375	7.000	7.625
Y . . . . .	FF FTF	25 $\frac{1}{4}$	27 $\frac{1}{4}$	29 $\frac{3}{8}$	31 $\frac{3}{8}$	33 $\frac{3}{8}$	37 $\frac{1}{2}$	41 $\frac{1}{2}$	45 $\frac{1}{2}$
ZZ (Lap or Polish) . . .	FF	6	6	6	6 $\frac{1}{2}$	6 $\frac{1}{2}$	6 $\frac{1}{2}$	6 $\frac{1}{2}$	6 $\frac{1}{2}$
Chamfer Collar . . . . .	FF FTF	$\frac{1}{32}$	$\frac{1}{32}$	$\frac{1}{16}$	$\frac{1}{16}$	$\frac{1}{16}$	$\frac{1}{16}$	$\frac{1}{16}$	$\frac{1}{16}$

# Shaft Dimensions for LG Bearings

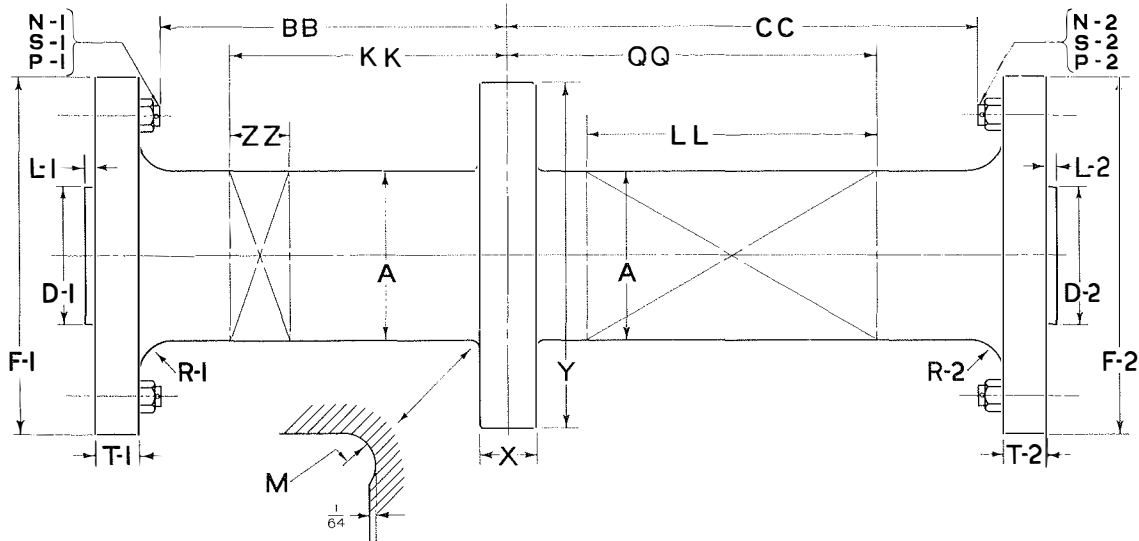

NOTE: Flange and bolt dimensions to be determined by the purchaser.

Caution: Before actual construction these dimensions should be confirmed by a certified print.

ALL DIMENSIONS ARE IN INCHES

Bearing Numbers	12	13½	15	17	19	21	23	25	27	29	31	33
A ± .001 . . . . .	5.250	5.625	6.500	7.500	8.500	9.000	10.250	10.875	12.125	12.875	13.625	14.375
	5.625	6.000	7.000	8.000	9.000	9.625	10.875	11.500	12.875	13.625	14.375	15.125
	6.000	6.500	7.500	8.500	9.625	10.250	11.500	12.125	13.625	14.375	15.125	15.875
	6.500	7.000	8.000	9.000	10.250	10.875	12.125	12.875	14.375	15.125	15.875	16.750
BB Min. Approx. . . .	13⅜	14¾	15⅝	17	17	19	20	21	22¼	23¼	25	26
CC Min. Approx. . . .	21¾	24¼	26	28½	29½	32	34¾	37	40	42	44¾	47¼
KK . . . . .	11¾	13	13⅞	15¼	15¼	16⅝	17⅝	18¾	20	21	22	23
LL (Lap or Polish) . .	13¾	15	16¼	18	19½	21	23	24½	27	28¾	29¾	31½
M (Fillet Rad.) . . . .	⅛	⅛	⅜	⅜	⅜	⅜	¼	¼	⅜	⅜	⅜	⅜
QQ . . . . .	20¼	22½	24¼	26¾	27¾	29¾	32½	34½	37½	39¾	42	44½
X . . . . .	2.000	2.250	2.500	2.875	3.250	3.625	3.875	4.250	4.625	5.000	5.250	5.625
Y . . . . .	12.188	13.688	15.188	17.250	19.250	21.250	23.250	25.250	27.250	29.375	31.375	33.375
ZZ (Lap or Polish) . .	4½	5	5	5	5	6	6	6	6	6½	6½	6½
Chamfer Collar . . . .	⅛	⅜	⅜	⅜	⅜	⅜	⅜	⅜	⅜	⅜	⅜	⅜

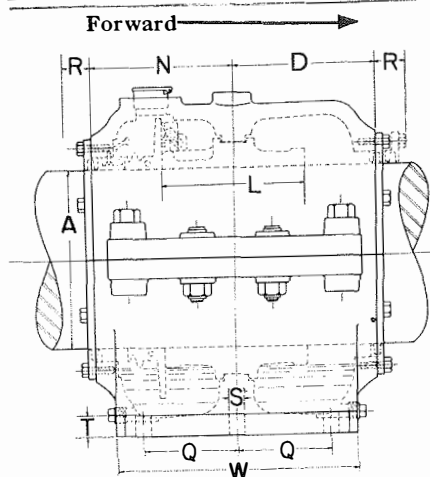

## Style LD Line Shaft Bearings

"LDS" bearings are special as to the dimensions in **bold** type. See page 11 regarding special shaft sizes.

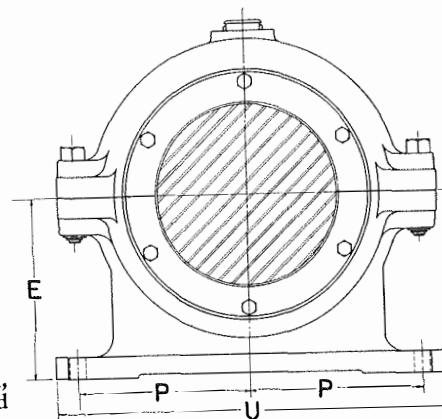

Caution: Before actual construction, these dimensions should be confirmed by a certified print.

Bearing Numbers . . . .	LD-8	LD-9	LD-10½	LD-12	LD-13½	LD-15	LDS-15	LD-17	LD-19
Drawing Number . . . .	6.000	7.000	7.500	8.500	9.625	10.875	463170	12.125	13.625
A Shaft Diameter . . . .	6.000 6.500	7.500	8.000 8.500	9.000 9.625	10.250 10.875	11.500 12.125	10,750	12.875 13.625	14.375 15.125
Wt., Bearing, complete . .	250	320	450	600	750	900	900	1150	1450
Wt., Spare Shell . . . .	55	75	100	140	180	220	220	280	370
D (to machined face) . . .	6¾	7	7½	8¾	8¾	9¾	8¾	10½	11½
E . . . . .	7¼	8	8¾	9¾	10¾	12	12	13¾	14¾
L . . . . .	6	6½	7¼	8	8¾	9¾	10¾	10¾	12
N (to machined face) . . .	6¾	7	7½	8¾	8¾	9¾	8¾	10½	11½
P . . . . .	8¼	8¾	9¾	10¾	11¾	11½	12½	12¾	13¾
Q . . . . .	2¾*	3*	3¼*	3¾*	4¼	6¼	6¼	6¾	7½
R (min. space to repack) .	1¾	1¾	1¾	1¾	2	2	2	2	2
S (bolt diameter) . . . .	¾	¾	1	1	1	1	1	1	1½
T . . . . .	1½	1½	1½	1¼	1¼	1½	1½	1¾	1¾
U (rough) . . . . .	19	20½	22½	24½	26½	26	28	28½	31
W (rough) . . . . .	11½	12¼	13	14	15	16	16	17¾	19½
Oil Capacity, gallons . . .	1¼	1½	2	2½	3	3½	3½	4½	6½

\*Two bolts each side. (Sizes 13½ and larger, 3 bolts.)

Bearing Numbers . . . .	LDS-19	LDS-19	LD-21	LD-23	LD-25	LD-27	LD-29	LD-31
Drawing Number . . . .	463185	363646	....	....	....	....	....	....
A Shaft Diameter . . . .	12,250	10,875	15.125 15.875 16.750	16.750 17.625 18.500	18.500 19.375 ....	19.375 20.250 21.250	21.250 21.625 22.500	22.500 23.125 24.000
Wt., Bearing, complete . .	1300	900	1800	2200	2600	3100	3600	4100
Wt., Spare Shell . . . .	370	....	450	575	720	900	1280	1300
D (to machined face) . . .	9¼	6	12¼	13¾	14	14¾	15½	16¾
E . . . . .	14¾	14¾	15½	16¾	18	19¾	20½	22
L . . . . .	12¼	8¼	13	14¼	15½	16½	17¾	19
N (to machined face) . . .	9¼	9	12¼	13¾	14	14¾	15½	16¾
P . . . . .	13	13	15	16	17	18¾	19½	20½
Q . . . . .	5¾	4⅝	8½	9	9¾	10½	11¼	12
R (min. space to repack) .	2½	2	2½	2½	2½	2½	2½	2½
S (bolt diameter) . . . .	1½	1½	1¼	1¼	1¼	1¼	1½	1½
T . . . . .	1¾	1¾	1¾	2	2½	2½	2¼	2¼
U (rough) . . . . .	30	30	33¼	35½	38	40½	43	45½
W (rough) . . . . .	16½	13½	21	22¾	24½	26	27¾	29½
Oil Capacity, gallons . . .	5½	4½	9	12	15	19	23	27

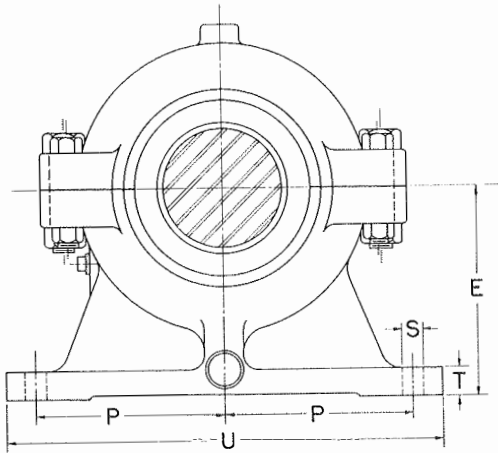

## Style L Bearings

See page 11 regarding shaft sizes.

End closures may vary to suit conditions.

Cut shows water thrower on left hand.

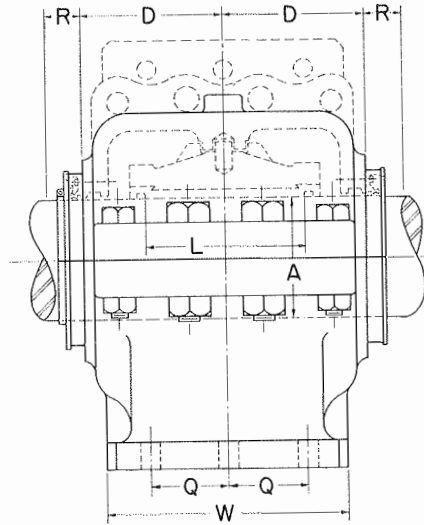

Caution: Before actual construction, these dimensions should be confirmed by a certified print.

Bearing Numbers . . .	L-8	L-9	L-10½	L-12	L-13½	L-15	L-17	L-19
A Shaft Diameters . . .	4.000 4.250	4.500 4.875	5.250 5.625	6.000 6.500	7.000 7.500	7.500 8.000	8.500 9.625	9.625 10.250
Wt., Bearing, complete . . .	130	180	270	395	550	760	1000	1300
Wt., Spare Shell . . .	30	40	68	110	155	210	300	400
D . . . . .	4½	5	5⅞	6⅞	7⅞	7¾	8½	9½
E . . . . .	7⅞	7¾	8¾	9⅞	10¾	12	13⅞	14¾
L . . . . .	5	5⅞	6¾	7¾	9	9½	10¾	12¼
P . . . . .	6	6¾	7⅞	8⅞	9⅞	10½	11⅞	13
Q . . . . .	2⅞	2⅞	3¼	3⅞	4	4½	4¾	5¾
R (space to repack) . . .	2¾	2¾	3	3	3¼	3¼	3½	3½
S (bolt diameter) . . .	¾	¾	⅞	⅞	1	1	1	1⅞
T . . . . .	1⅞	1⅞	1¼	1¼	1½	1½	1¾	1¾
U (finished) . . . . .	14¼	16	18¼	19¾	22¼	24	27	29¼
W (rough) . . . . .	7⅞	8¾	10	10¼	12	13½	14¾	16¾
Oil Capacity, gallons . . .	1¼	1½	1¾	2	2½	3	4	5

Bearing Numbers . . .	L-21	L-23	L-25	L-27	L-29	L-31	L-33
A Shaft Diameters . . .	10.250 10.875	11.500 12.125	12.125 12.875	13.625 14.375	14.375 15.125	15.125 15.875	16.750 17.625
Wt., Bearing, complete . . .	1800	2400	3000	3800	4800	5800	7000
Wt., Spare Shell . . .	550	700	880	1080	1320	1600	1860
D . . . . .	10⅞	11¼	12	13⅞	13¾	15	16
E . . . . .	15½	16¾	18	19⅞	20½	22	23¼
L . . . . .	13	14½	15½	17¼	18⅞	19	21⅞
P . . . . .	14⅞	15⅞	16⅞	17⅞	19½	20¾	22 (4 bolts)
Q . . . . .	6½	7	7¼	10¼	4 bolts, optional spacing	4	5
R (space to repack) . . .	4	4	4	4	4	4	
S (bolt diameter) . . .	1¼	1¼	1¼	1½	1½	1½	1½
T . . . . .	1⅞	1⅞	2⅞	2⅞	2¼	2¼	2⅞
U (finished) . . . . .	32	34½	37½	40	43	45½	48
W (rough) . . . . .	18½	19¾	21	23	24½	26	27½
Oil Capacity, gallons . . .	6½	8	10	12	14½	17	20



Figure 16  
Line Shaft Bearing and Combined  
Thrust and Journal Bearing.

## Rated Capacities of Journal Bearings (in Pounds)

At any speed, the capacity of a given journal bearing is nearly proportional to the oil viscosity. Large bearings carry greater loads per square inch than small ones.

For each speed tabulated below, the capacity is stated at two viscosities, 150 and 300 seconds Saybolt, *at the operating temperature*. Capacities for other speeds and other viscosities are easily interpolated. For bearings whose lengths are

more or less than the diameter, apply the Rating Factors at lower right. Long bearings frequently wear unevenly due to natural shaft flexure. Our standard L and LD bearings should not be loaded over 400 pounds per square inch of projected area, even when supplied with very heavy oil. Consult us about heavy loads and other unusual conditions, such as very high or very low speeds.

TABLE II

Journal Dia.	Capacities of Bearings for which Length equals Diameter								Max. Cap'y* with suit- ably heavy lubricant
	100 R.P.M.		200 R.P.M.		500 R.P.M.		1000 R.P.M.		
	Saybolt 150	Saybolt 300	Saybolt 150	Saybolt 300	Saybolt 150	Saybolt 300	Saybolt 150	Saybolt 300	
5¼	820	1,640	1,080	2,160	1,560	3,120	2,080	4,160	11,000
5½	980	1,960	1,300	2,600	1,880	3,760	2,480	4,960	12,700
6	1,160	2,320	1,520	3,040	2,200	4,400	2,900	5,800	14,400
6½	1,400	2,800	1,850	3,700	2,700	5,400	3,550	7,100	16,900
7	1,700	3,400	2,250	4,500	3,200	6,400	4,250	8,500	19,600
7½	2,000	4,000	2,650	5,300	3,850	7,700	5,100	10,200	22,500
8	2,350	4,700	3,150	6,300	4,500	9,000	6,000	12,000	25,500
8½	2,750	5,500	3,650	7,300	5,250	10,500	7,000	14,000	28,900
9	3,200	6,400	4,250	8,500	6,100	12,200	8,000	16,000	32,400
9¾	3,750	7,500	5,000	10,000	7,200	14,400	9,500	19,000	37,100
10¼	4,450	8,900	5,900	11,800	8,400	16,800	11,100	22,200	42,200
10¾	5,100	10,200	6,800	13,600	9,800	19,600	13,000	26,000	47,500
11½	5,900	11,800	7,800	15,600	11,200	22,400	14,700	29,400	53,000
12¼	6,700	13,400	9,000	18,000	12,500	25,000	16,500	33,000	58,900
12¾	7,800	15,600	10,400	20,800	14,900	29,800	19,500	39,000	66,500
13½	9,100	18,200	12,000	24,000	17,000	34,000	22,500	45,000	74,100
14¾	10,200	20,400	13,600	27,200	19,500	39,000	25,700	51,400	82,800
15½	11,700	23,400	15,500	31,000	22,000	44,000	29,000	58,000	91,600
15¾	13,200	26,400	17,500	35,000	25,000	50,000	These ratings are suitable for bearings whose length equals the diameter. For other lengths, apply the rating factors below.		
16¾	15,000	30,000	20,000	40,000	28,500	57,000			
17¾	17,500	35,000	23,000	46,000	33,000	66,000			
18½	19,500	39,000	26,000	52,000	37,000	74,000	L D	Rating Factor	
19¾	21,500	43,000	28,500	57,000	41,000	82,000			
20¼	24,000	48,000	32,000	64,000	.....	.....	0.8	0.63	
21¼	27,500	55,000	36,500	73,000	.....	.....	1.0	1.00	
22¼	30,500	61,000	50,400	81,000	.....	.....	1.2	1.42	
23¼	34,500	69,000	45,500	91,000	.....	.....	1.5	2.07	

\*These values are given to illustrate the high limits of inherent capability. They are not recommended for actual application.

---

---

## Spare Parts

A Kingsbury Bearing correctly chosen, properly aligned and supplied with clean oil, is practically indestructible for the life of the ship. However, spare parts are customarily provided as a matter of insurance.

For marine machinery, American Bureau of Shipping rules will usually determine what

spare parts are required. The usual spares are thrust shoes, occasionally seal packing, and also journal bearing shells and cooler parts where fitted.

The other parts of the bearing practically never need replacement. Therefore, there is no need to carry *complete* bearings as spares.

## Engineering Data Needed with Orders

- (A) Thrust load\* (maximum).
- (B) Journal bearing load (if unusually heavy).
- (C) Shaft diameter through bearing.
- (D) Revolutions per minute (at full power).
- (E) Is cooling water available?
- (F) Is external lubricating system available?
- (G) Sketches showing unusual mounting conditions, space limitations, etc.
- (H) Bearing number contemplated (e.g. LG-25, L-27, etc., etc.).
- (J) Spare parts requirements.

\*For propeller thrust service, if load is unknown, give horsepower per shaft, vessel speed, and type of vessel.

\*For dredge pump service, if load is unknown, give horsepower, impeller outside diameter, and diameter of eye (suction opening in impeller.)

## Standard Guarantee

Any bearing or part furnished by us, which shall prove defective in design, material or workmanship, within one year after installation and test, will be replaced without charge f.o.b. Philadelphia, if returned to our factory. This period is, however, limited to a maximum of two years from date of shipment from the

factory. No allowance will be made for labor or other expense in connection therewith unless authorized in writing by an officer of the Company.

For oil coolers and cooling coils, in accordance with usual trade practice, there is no specific guarantee period.

