

KINGSBURY BEARINGS

**for
Turbines,
Steam and Gas**

Bulletin T

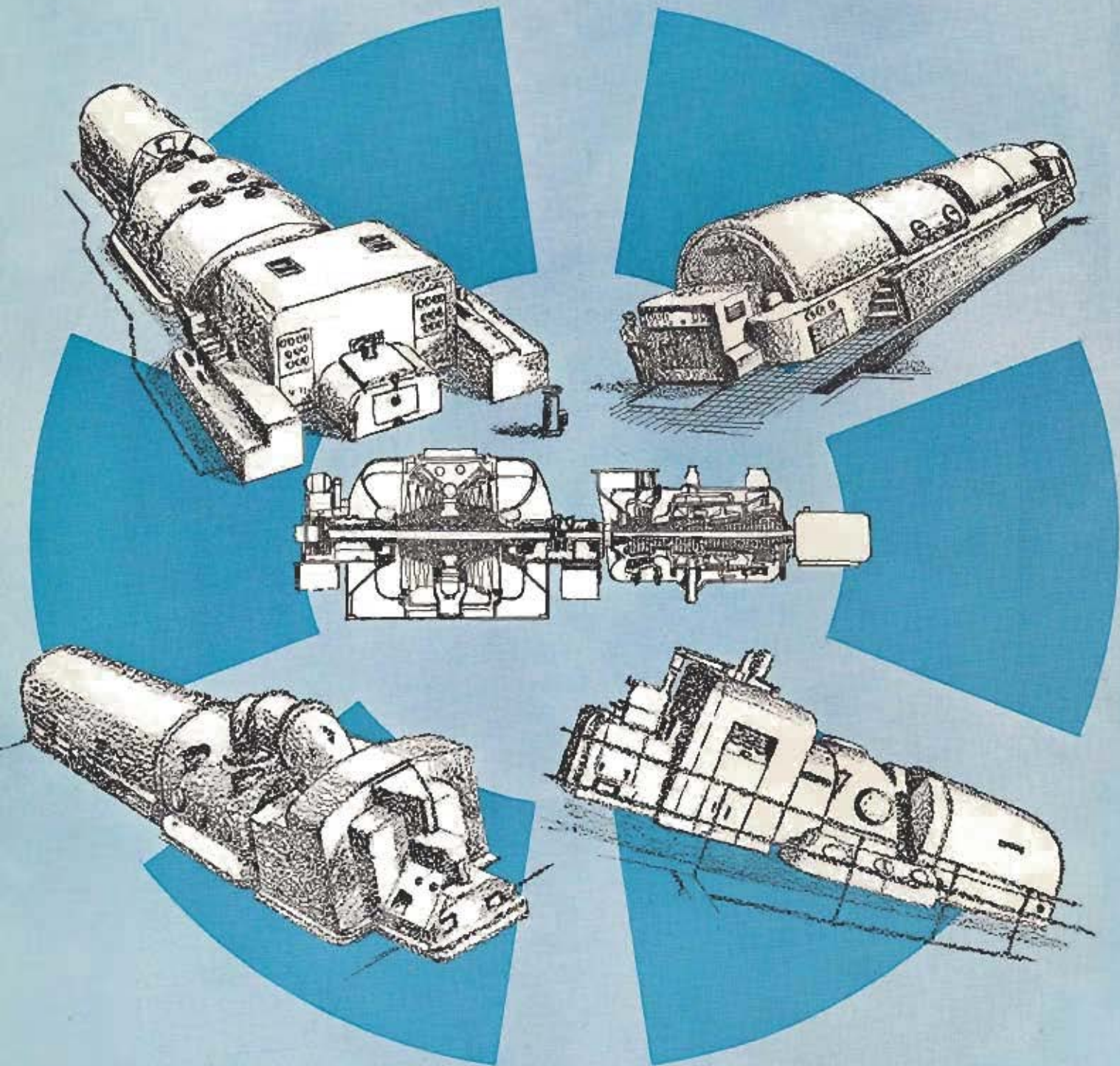



KINGSBURY

Thrust and Journal

BEARINGS

for

TURBINES

Steam and Gas

BULLETIN T



KINGSBURY MACHINE WORKS, INC.

Main Office and Works

FRANKFORD, PHILADELPHIA 24, PA.

CONTENTS

| | |
|---|----|
| Foreword | 5 |
| Turbine Thrust Bearing Requirements | 6 |
| Basic Elements | 7 |
| The Shoes and Their Backing | 7 |
| Types of Bearings Described | 10 |
| The Oil Control Ring—What It Does. | 11 |
| Oil Control Ring Bearings | 12 |
| Two-Collar Type Bearings | 13 |
| Cage Type Thrust Bearings | 14 |
| One-Way Thrusts | 16 |
| Vertical Turbine Thrusts | 17 |
| Lubrication and Cooling | 19 |
| Symbols for Standard Designs | 20 |
| Journal Bearings. | 22 |
| Spare Parts | 24 |
| Data Needed for Inquiries | 24 |
| Standard Guarantee | 24 |

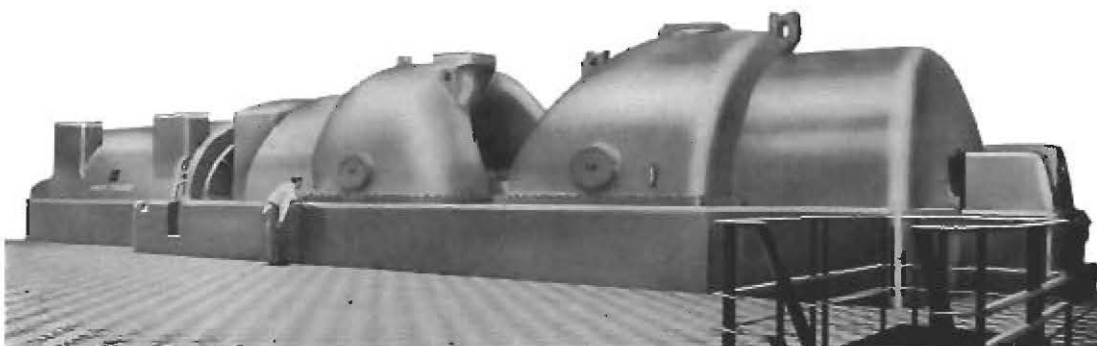

Clifty Creek Unit No. 1. 217260-kw cross-compound turbine generator unit. H.P. turbine 3600 rpm, L.P. turbine 1800 rpm.

Photos, courtesy American Gas & Electric Service Corp. and the General Electric Co.

FOREWORD

The turbine is essentially a high-speed continuous service machine which poses some of the most difficult problems of control and lubrication met with in the prime mover field. Whether driven by steam or gas, the operating conditions imposed by the requirements of efficiency and compactness involve high temperatures at the inlet end, resulting in transfer of heat to all parts adjacent to the cylinder structure. In consequence the thrust and journal bearings at the inlet end of such a machine are subjected not only to the heat equivalent of bearing friction, but also to the heat transmitted from the turbine casing.

Under these severe conditions Kingsbury bearings outperform all other types. As an inherent feature of their design, a continuous flow of oil passes between the working surfaces, separating them and preventing metallic contact, also carrying away the heat of friction and transmitted heat. A variety of bearing types and arrangements is supplied to meet different conditions of size, speed and installation.

This booklet is devoted specifically to thrust bearings and journal bearings suitable for this type of application, either land or marine, both in horizontally disposed units of any size and in small vertical units such as are employed in high-speed pump and blower drives.

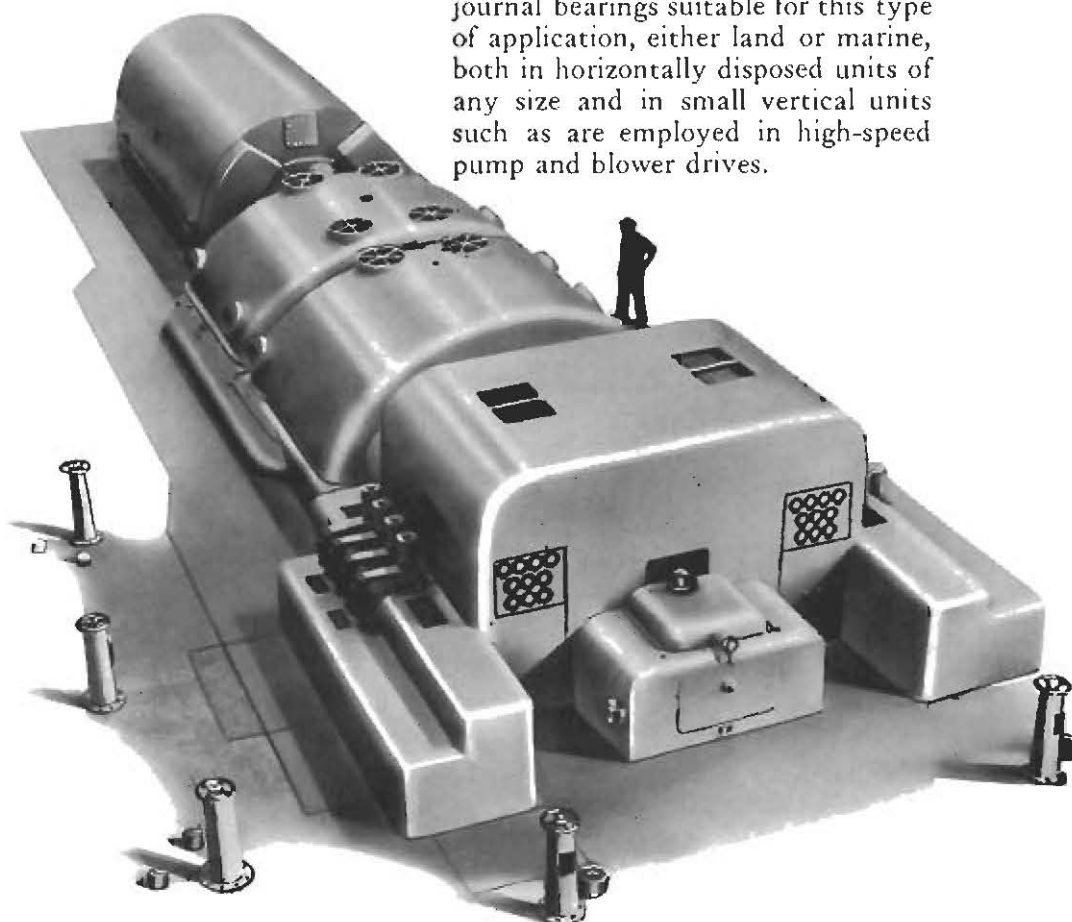

Meramec Station Unit No. 1. 110,000-kw tandem compound turbine generator unit, triple flow. Union Electric Co., St. Louis, Mo.
Photo, courtesy Westinghouse Electric Corp.

TURBINE THRUST BEARING REQUIREMENTS

There are two principal requirements which must be met by any bearing used in a steam or gas turbine application. The first is: the ability to carry load without distress as long as the turbine remains in operation. This is readily fulfilled by Kingsbury Thrust and Journal Bearings as long as an adequate supply of cool lubricating oil is fed to the operating surfaces. Because it is characteristic of the design that the stationary and moving surfaces are always separated by continuously self-renewing oil films, there is no metallic contact in normal operation and hence no wear. Operating maintenance is confined to furnishing the required flow of clean filtered oil, properly cooled.

The second requirement is that the power loss in the bearing shall be kept to the smallest practicable value. This requirement, for any given application, is met by choosing that one of the several available styles of bearing that is most suitable for the load and speed involved, so as to minimize unnecessary churning and heating of the oil.

A third requirement is accessibility. In this respect no other type of bearing can rival the Kingsbury because, where necessary, a split construction can be used so that the thrust bearing parts can be inspected or removed without lifting the turbine shaft.

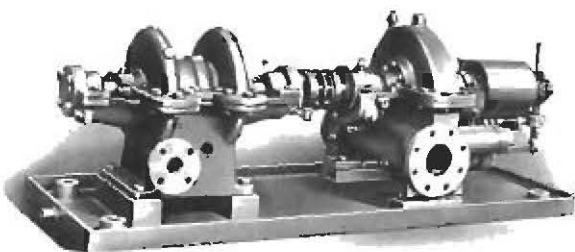
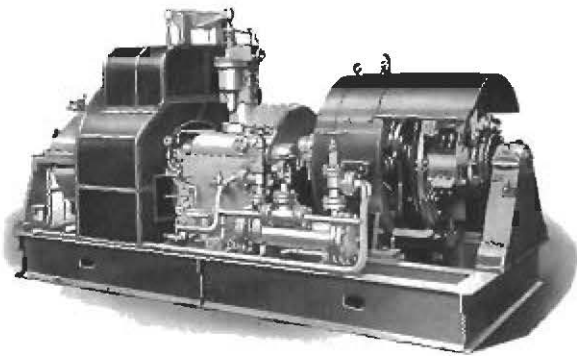

Typical turbine-driven auxiliary units.

Photos, courtesy Westinghouse Electric Corp

BASIC ELEMENTS

The basic elements of a Kingsbury Thrust Bearing are:

- (1) The stationary pivoted *Shoes*.
- (2) The *Thrust Collar*, which rotates with the shaft and applies the load to the shoes (called *Runner* in vertical bearings).
- (3) The *Base Ring* or other means of supporting the shoes and equalizing the shoe loads.
- (4) The *Housing*, or mounting, which contains and supports the internal bearing elements.
- (5) The *Lubrication System*, which continuously floods the collar and shoes with oil.
- (6) The *Cooling System* for removing the heat caused by oil friction.

Every thrust bearing installation involves all of these elements in one form or another. Designs may be classified as horizontal or vertical, and according to the number of shoes.

THE SHOES AND THEIR BACKING

Before passing on to the various combinations of the above elements in particular types of bearings, the general form of the shoes should be noted; also the different methods of supporting them and dividing the load among them.

The Shoes

The shoes are segmental. Standard bearings have from two to eight shoes in each side according to type, arranged as diagrammed in Figure 2.

Every shoe has a pivoted "shoe support." Usually the support is set into the back of the shoe and has a hardened, slightly rounded pivot which contacts a hardened backing surface. A small shoe and its support are shown at the left in Figure 1.



Figure 1

Three pivoted shoes (a fourth is inverted to show the hardened steel "shoe support" set into its base).

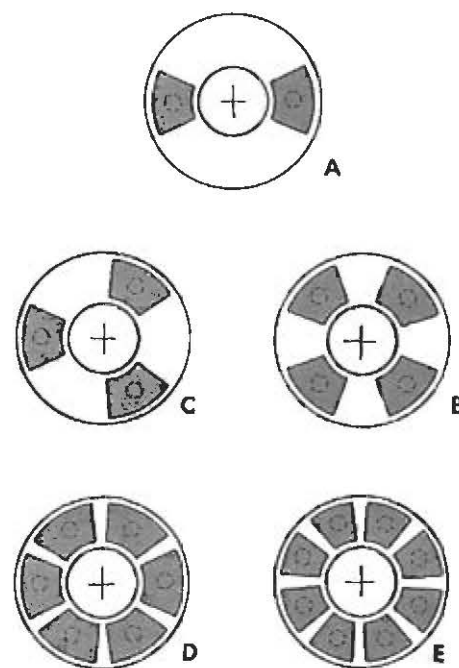

Figure 2

Diagram of shoe arrangements in Kingsbury Thrust Bearings.

- A — Two-shoe equalizing arrangement.
- B — Four shoes, equalizing, for small bearings.
- C — Three shoes for standard equalization by leveling washers.
- D — Six shoes in standard equalizing bearings, horizontal or vertical.
- E — In special cases, equalizing bearings may use eight instead of six shoes.

Equalizing Bearings

Two principal methods of equalization are used. They are illustrated in Figures 4-9.

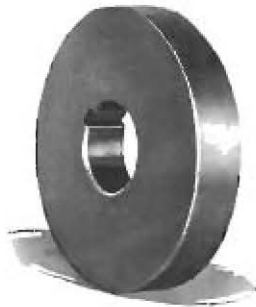

Figure 3
Standard (removable) collar for bearings with horizontal shaft.

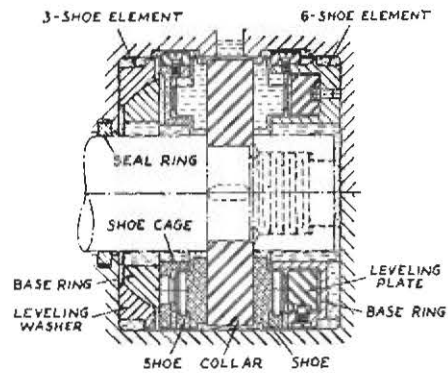

Figure 7
Three-shoe and six-shoe double horizontal thrust bearing elements.

For the three-shoe bearings shown in Figure 5, the equalizing means consist of a "solid" (i.e., one piece) spherically-seated "base ring" and solid "leveling washer," shown in the left side of Figure 7. These three-shoe bearings are used only in small to medium sizes. They may be either horizontal or vertical.



Figure 4
Standard three-shoe equalizing bearing with shoes removed, showing hardened steel support plugs in shoe cage.

For six-shoe and eight-shoe bearings and the occasional four-shoe applications, the loads are equalized by a series of interlocking levers, or "leveling plates," as shown in Figures 8 and 9.

Figure 5
Three-shoe bearing. For vertical or horizontal shaft.

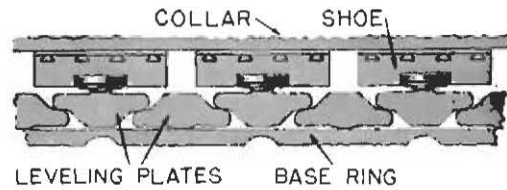

Figure 8
Developed diagram showing principle of equalized support of shoes by use of leveling plates.



Figure 6
3-shoe bearing for vertical shaft. Arrows show direction of oil flow.



Figure 9
Split base ring and leveling plates of small six-shoe bearing. A "lower" leveling plate is shown separately.

The shoes bear against the "upper" plates. The "lower" plates rock very slightly, on radial ribs formed on their under surfaces, until every shoe bears an equal share of the load.

The leveling plates are loosely held in a "base ring," which may be in one piece for assembling over the end of the shaft, or split (as in Figure 9) for radial assembling. The whole assembly (Figures 10, 11) of base ring leveling plates and shoes, with collar or runner, is mounted in a housing, and the lubricating and cooling systems are designed to suit the application, horizontal

or vertical, as required. The bearing may be "single" for unidirectional loading, or "double" for two-directional loading; or a six-shoe bearing for the main thrust may be combined with a three-shoe or two-shoe bearing for a lighter reverse load, or simply to limit end movement.

For light loads the equalizing type of two-shoe bearing was developed. It is often used on the unloaded side in pump thrust bearings; also for compressors. Being of split construction it can be assembled over a shaft with an integral collar, which cannot be done with the three-shoe type.



Figure 10
Small (6-shoe) thrust bearing for vertical shaft. Arrows show direction of oil flow, inward at bottom of base ring, outward between shoes.

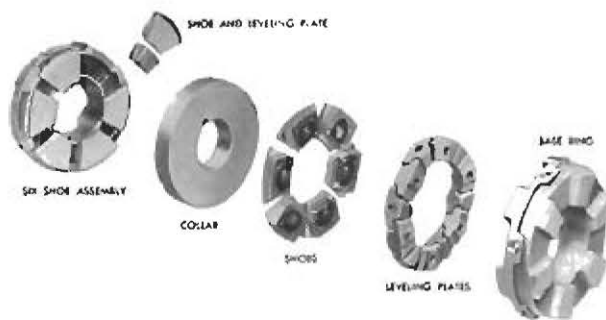

Figure 13
Small double (two-way) six-shoe thrust bearing. Near-side elements "exploded"; far-side elements assembled.



Figure 11
Six-shoe bearing assembly. (Shoes added to Fig. 9 parts). For vertical or horizontal shaft.



Figure 12
Small two-shoe equalizing bearing for light loads. The split base ring rocks on a blunt knife-edge at right angles to the shoes.

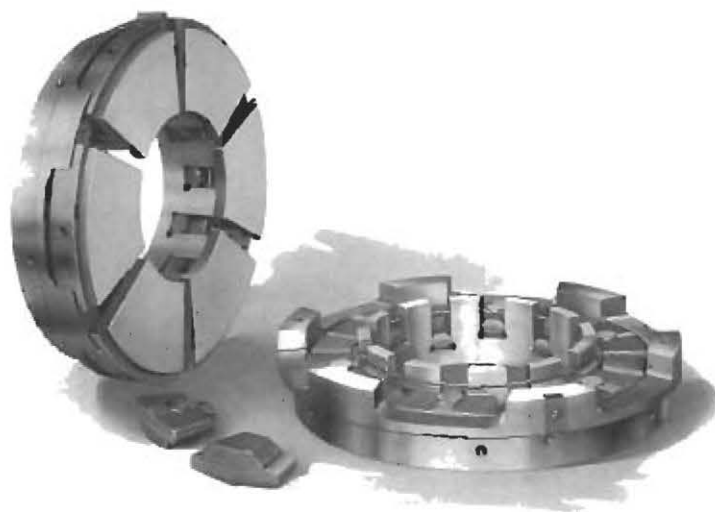

Figure 14
Large double six-shoe bearing, without collar. Base rings solid. Shoes of nearer set are omitted to show leveling plates. Two leveling plates (upper and lower) shown separately.

TYPES OF BEARINGS DESCRIBED

A number of types of bearings are described in the following pages, indicating the degree of diversification that has been attained to serve the many kinds of application in the turbine field. The principal standard types are listed below, but it is hardly necessary to point out that Kingsbury's engineering staff are always willing to study special situations and to produce bearings that will satisfy the specified conditions.

The bearing styles hereinafter discussed are as follows:

Horizontal Units

For high speeds:

- Oil Control Ring Bearings
- Sleeve Type Bearings
- Two-Collar Type Bearings

For moderate speeds:

- Cage Type Bearings

For gas turbine and compressor applications:

One-way Thrust Bearings

Vertical Units

- Flooded Lubrication Type Bearings
- Oil Control Ring Bearings

Journal Bearings

- Self-aligning Journal Bearings (Bracket Type)
- Combined thrust and segmental pivoted-shoe journal bearings for high speed.

Dimensional data, weights and capacity information for many of the bearing types listed above are available in our catalog for equalizing bearings, which may be had upon request.

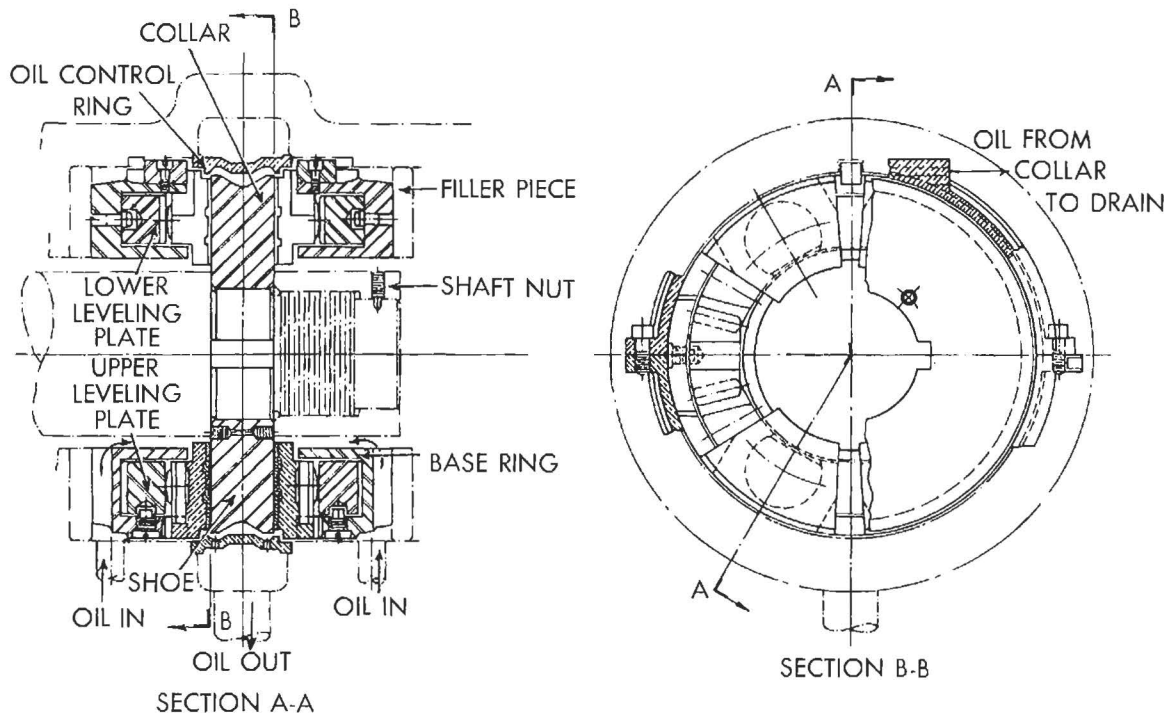

Figure 15

6 x 6 horizontal bearing with oil control ring; thrust collar mounted on end of turbine shaft.

THE OIL CONTROL RING—WHAT IT DOES

The purpose of the oil control ring is to cause the oil to be expelled from the thrust bearing immediately after it has passed between the working surfaces and has absorbed the heat of oil shear. To accomplish this the oil is introduced into the bearing at, or below, the level of the shaft center. It flows into the spaces between the shoes and between the shoes and the thrust collar. Upon squeezing out at the trailing edges of the shoes it is whirled outward by the collar rim into a ring surrounding the collar, at the top of which it is ejected tangentially through discharge openings, as if from a centrifugal pump. Thence it drains into the housing and is returned to the oil reservoir.

As the result of this action the oil is carried away as rapidly as it performs its lubricating and cooling functions and is not permitted to mix with incoming oil or to be churned around in the



Figure 17
Photograph of assembled oil control ring.

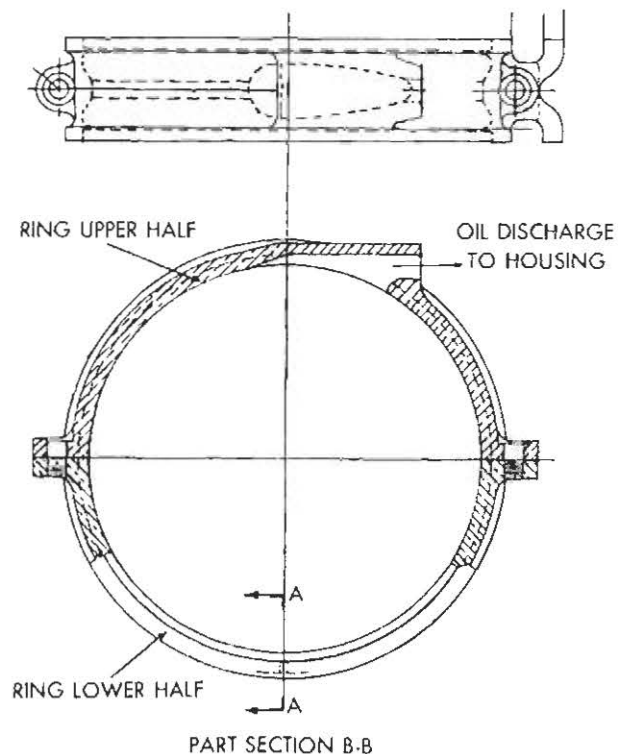

Figure 16
Sectional assembly of typical oil control ring.

bearing cavity. It will be understood, upon reflection, that under these circumstances there can be no standing oil level in the bearing cavity while running and the oil escapes, immediately its work is done, carrying with it the heat developed by oil shear and that transmitted by radiation from the turbine cylinder.

The thrust cavity is closed by oil seal rings on both ends of the bearing and the housing is so arranged that, when the shaft stops, oil will be retained in the lower half of the thrust cavity. When the turbine is restarted, the surplus oil is promptly expelled by the spinning collar.

Oil control ring bearings are available in standard sizes suitable for a wide range of high-speed service, such as for marine propulsion turbines and also for turbines driving auxiliary apparatus. Catalog information on capacities and dimensions will be furnished upon request.

OIL CONTROL RING BEARINGS

A typical oil control ring bearing is illustrated in Figure 18. The control ring, surrounding the bearing collar, is made in halves for accessibility and is held in the housing by ears, or lugs, that fit into recesses in the housing flange and prevent the ring from rotating. Oil reaches both sides of the collar from inlet openings at or near the bottom of the bearing cavity in the usual manner, passing through grooves in the backs of the base rings to the shaft and thence along to the collar faces.

The oil control ring itself is shown in the photograph, Figure 17, and drawing section, Figure 16, and comparison of these pictures with drawing of Figure 18 will make quite clear the manner in which the ring directs the flow of the

lubricant to remove it from the working space with a minimum of disturbance.

It will be obvious from the above that there must be no restriction of the outlet passages or the purpose of the ring would be defeated. Contrariwise, the area of the oil inlets and the lubricating system pressure should be so adjusted as to insure an adequate, but not excessive, supply to the bearing.

While the provision of an oil control ring permits the use of the simplest housing design, the same effect can be approximated by providing suitable grooves in the housing, with tangential discharge at the top. This arrangement is shown in Figure 23.

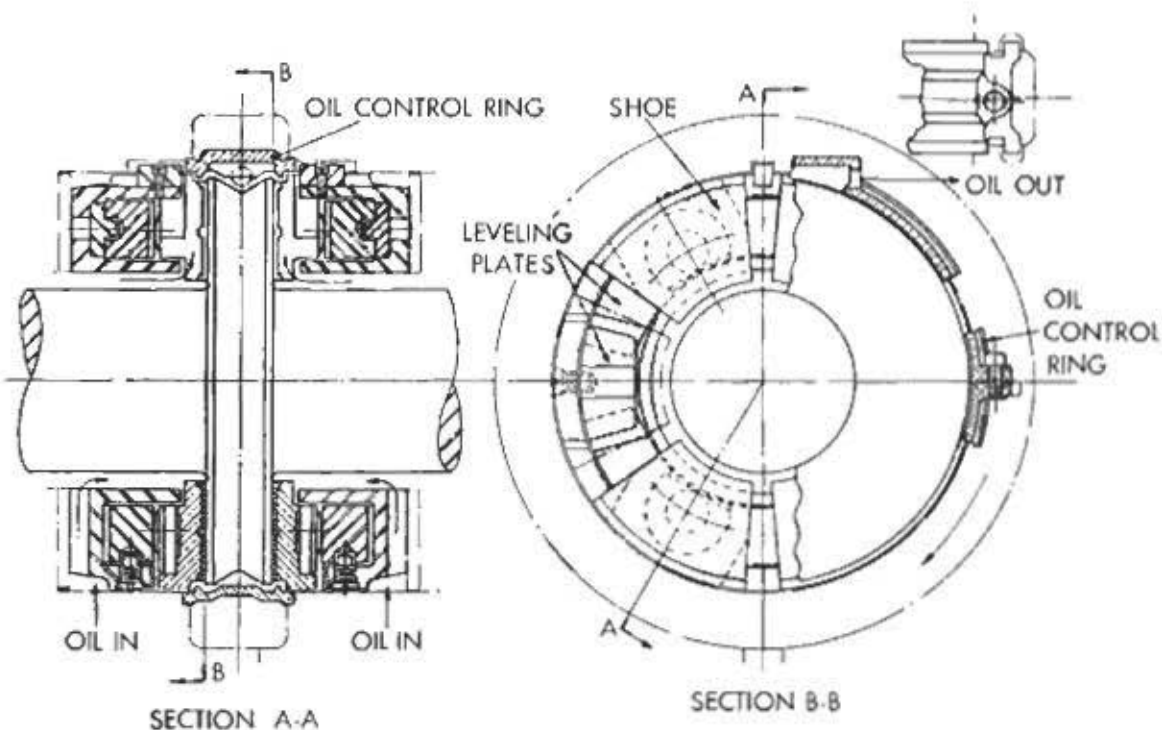

Figure 18

Typical double shoe bearing with oil control ring, thrust collar integral with shaft.

TWO-COLLAR TYPE BEARINGS

A specially compact bearing, embodying the oil control principle, but in modified form, is shown in Figure 20. This type of bearing is particularly adapted to the requirements of high-speed turbine-driven pumps.

As may be seen in the illustration, two thrust collars are used and the bearing parts are located back to back between them in a base ring structure which also forms the shell of a journal bearing. Each collar with its respective thrust bearing parts is surrounded by a split bronze case made in halves. This casing is slotted at the top in line with the collar face so that the oil thrown from the collar rim is discharged tangentially into an annular space in the housing leading to the oil discharge connection.

The oil supplied to the bearing is fed first to the journal bearing. Thence all except the amount needed to lubricate the journal bearing passes, by way of grooves and drilled outlets, horizontally between the shoes to the collars. There it supplies the oil films between the shoes and the collars and, reaching the collar rims, is thrown outward through the discharge slots and runs down outside the casing to the drain. The rate of flow is adjusted so as to carry off the heat of oil friction with a predetermined moderate rise in temperature.

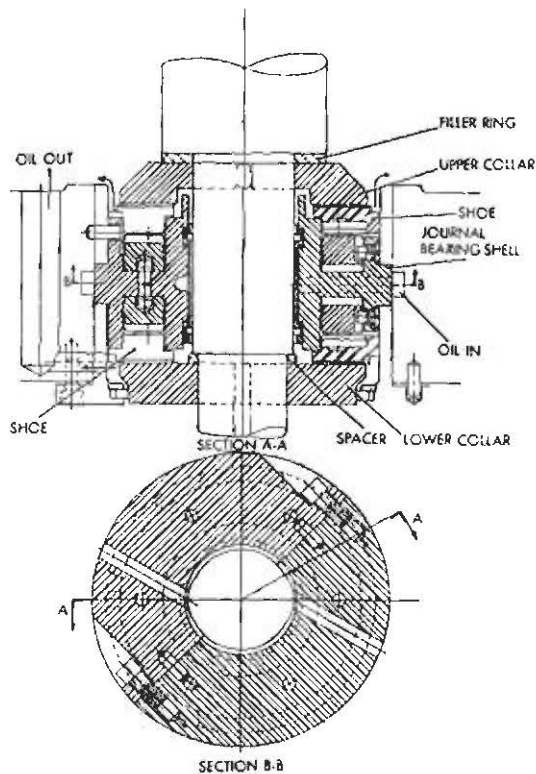

Figure 19
Two-collar thrust bearing in vertical application.
Bearing parts enclosed by apparatus housing.

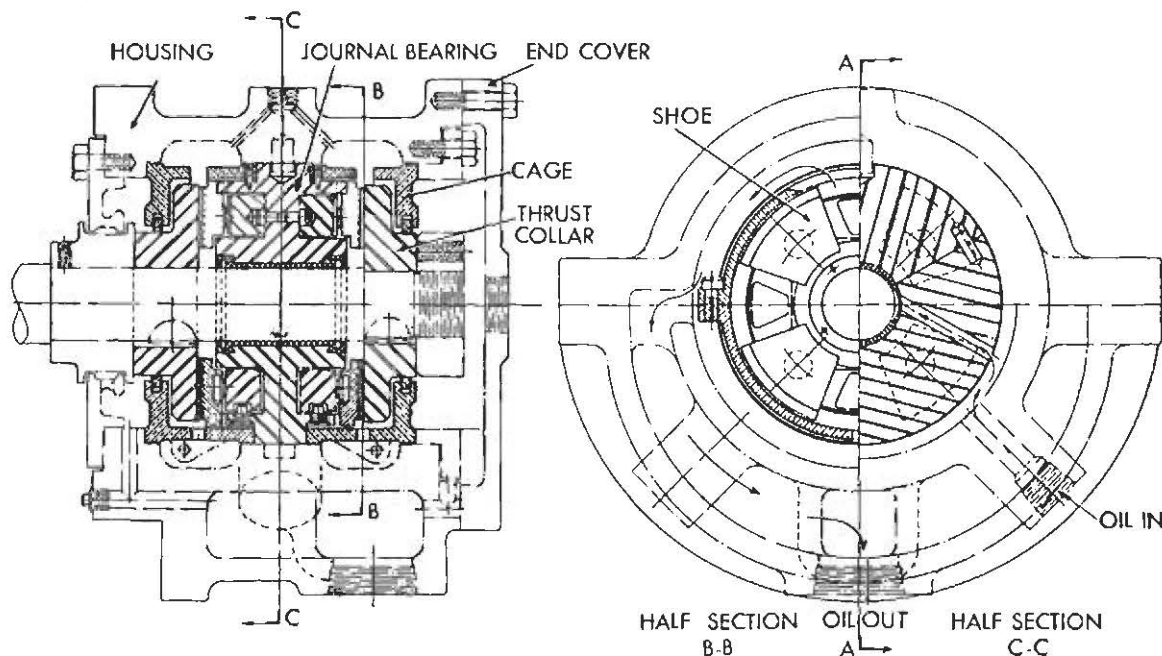

Figure 20
Two-collar bearing in horizontal unit. Bearing parts enclosed in separate casing.

There is, of course, no "oil level" when running, because the oil, when it has wet the working surfaces, is immediately expelled; but the housing is designed so that when the unit is stopped, oil is trapped in the thrust cavity to

provide a supply of lubricant for the next start.

Seal rings are provided to confine the oil to the working spaces. All the bearing parts except the seal rings and the thrust collars are removable radially when the housing cover is lifted.

CAGE TYPE THRUST BEARINGS

For applications where the thrust bearing is mounted at the end of the turbine shaft, the entire thrust bearing element can be surrounded by a container, or "cage," which can be secured to the housing by means of an external flange, and closed at the outer end by a cover plate. This arrangement permits the whole bearing assembly to be handled as a unit on the rotor shaft, if desired.

The cage is designed to be set into a recess in the end of the turbine bearing pedestal. It is a one-piece flanged steel forging. Its outer end is closed by a cover plate, and a filler ring between the cover plate and the cage determines the internal axial clearance, or "end play," of the bearing. Similarly, a liner between the cage flange and the pedestal and its cover determines the axial location of the turbine rotor in the housing.

These cage type bearings are usually of the double three-shoe or six-shoe and three-shoe

design. If six shoes are used on the side having the heaviest loading, that side will be of the leveling-plate equalizing design. When three shoes are used, on either or both sides, they are supported on a spherically seated base ring and leveling washer. Typical examples of both kinds are shown in Figures 21 and 22.

The cage design can be adapted for oil control, or "low power loss," operation by providing a Vee groove in the thrust collar and leaving room for tangential discharge of oil from a slot in the top of the cage. This is illustrated in Figure 23.

In all bearings of the cage type, openings are provided through which the thrust shoes can be inserted or withdrawn. However, complete assembly or disassembly must be accomplished from the end, removing first the outer shoe assembly, then the collar, then the inner shoe assembly, and finally the cage.

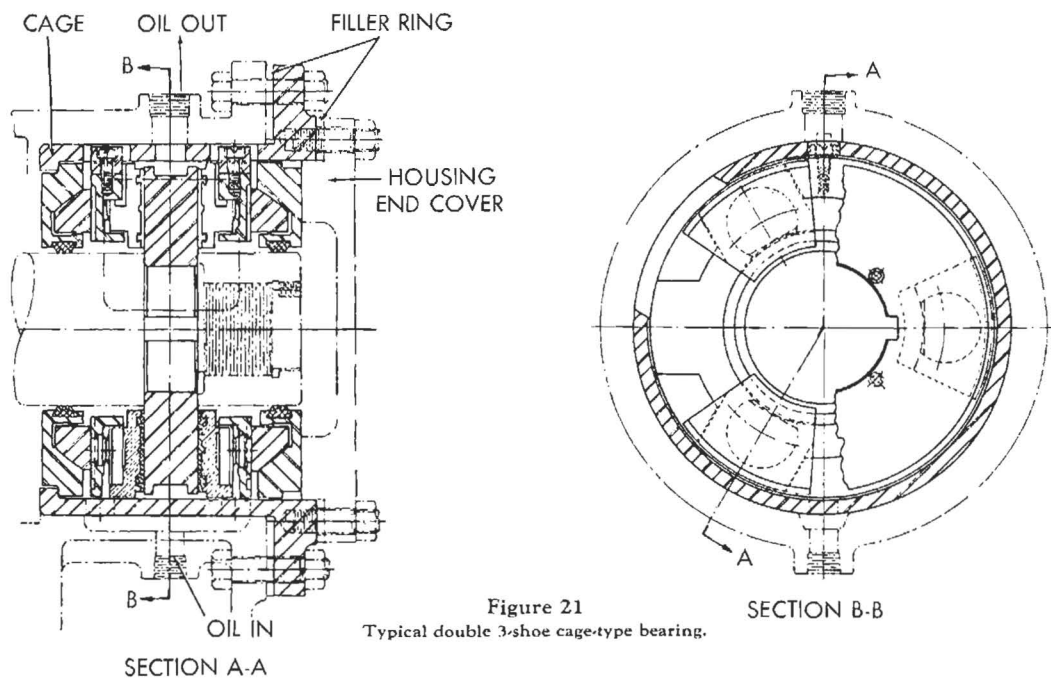

Figure 21
Typical double 3-shoe cage-type bearing.

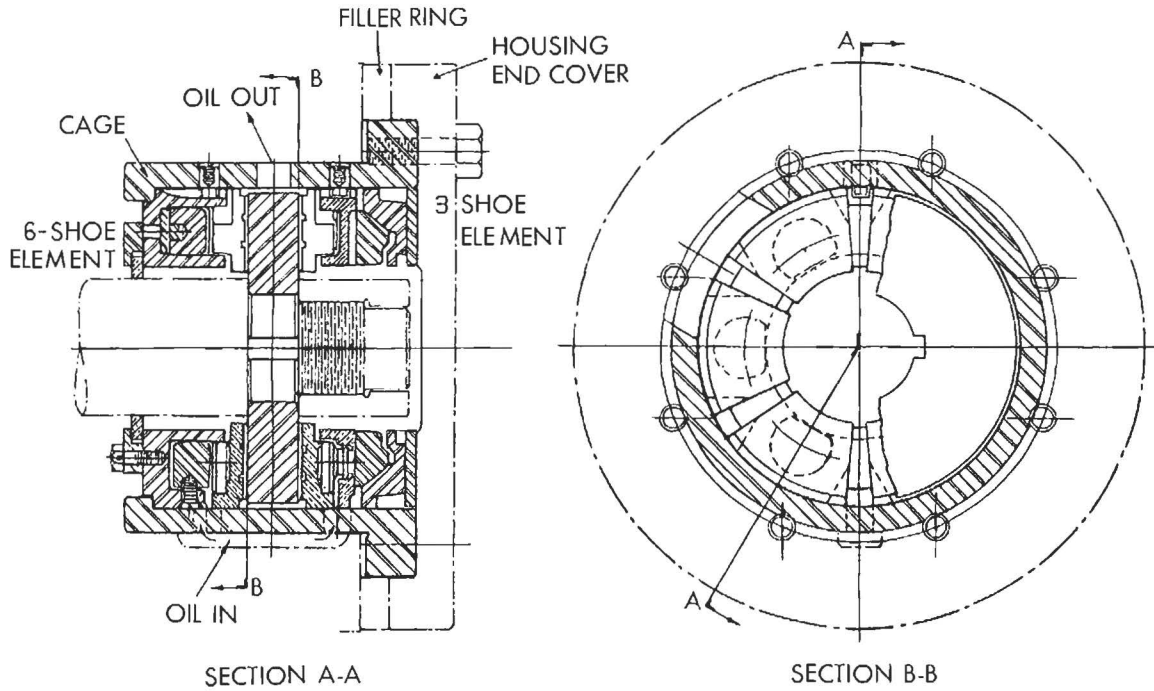

Figure 22
6-shoe and 3-shoe cage-type bearing. Major thrust is toward left.

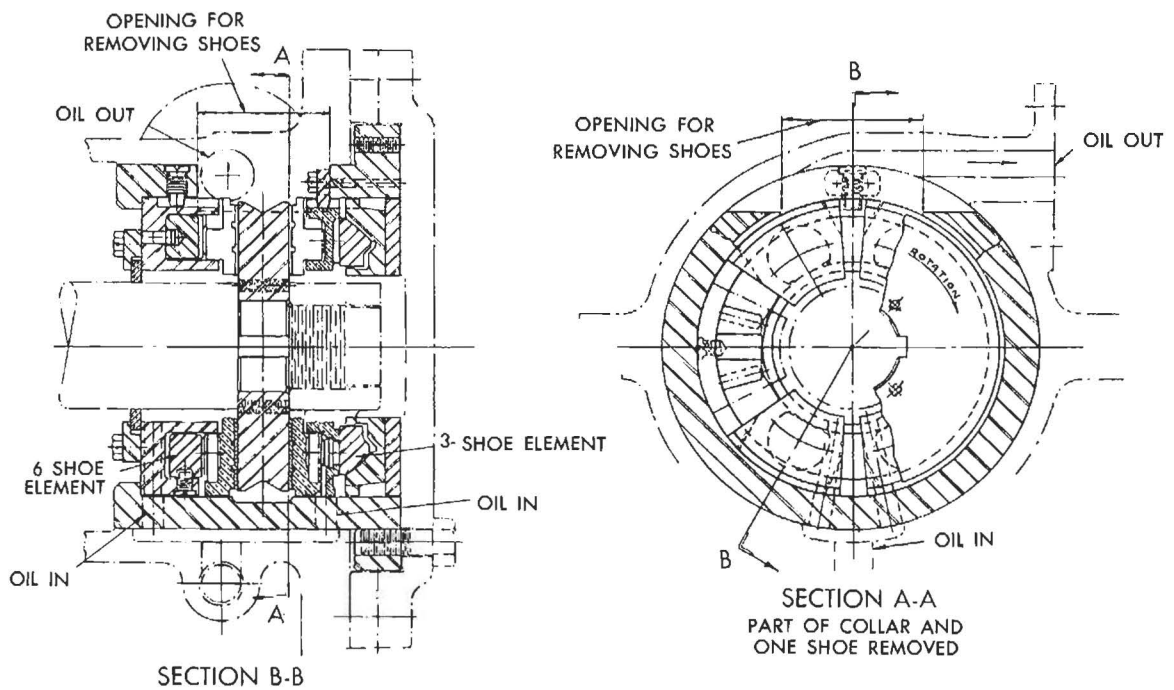

Figure 23
3-shoe and 6-shoe cage-type bearing arranged for low power loss at high speed.

ONE-WAY THRUSTS

There is a growing field of application of a specialized kind in thrust bearings for blowers and axial compressors, especially in connection with the rapidly expanding gas turbine enterprise. Units of this type are subjected to unidirectional thrusts, and the construction is often of such character that the thrust unit must be assembled endwise in a housing that is not split horizontally.

For such installations, one-way thrust bearings are available in two-shoe, three-shoe and six-shoe arrangements. A typical two-shoe unit is shown in Figure 24 and a six-shoe bearing in Figure 25. Although Figures 24 and 25 indicate collars separate from the shaft, bearings of this type are usually furnished without collar, as the collar is quite often an integral part of the shaft.

While the thrust in these applications is unidirectional and only one set of thrust bearing elements is required, nevertheless it is often necessary to limit the axial "float" of the shaft when running unloaded, and this is generally done by means of a simple "bumper" bearing on the unloaded side of the collar.

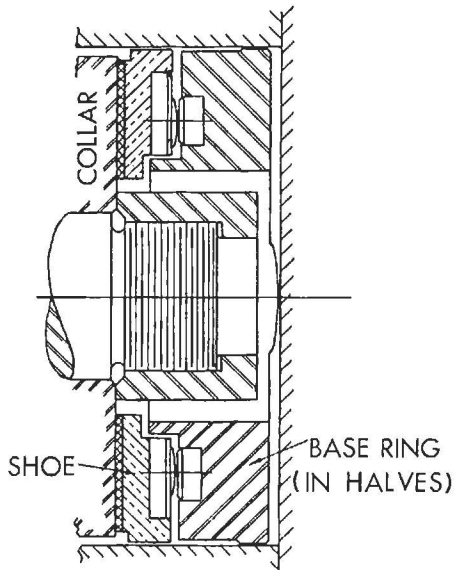

Figure 24
Diagram of equalizing means for 2-shoe thrust bearings.

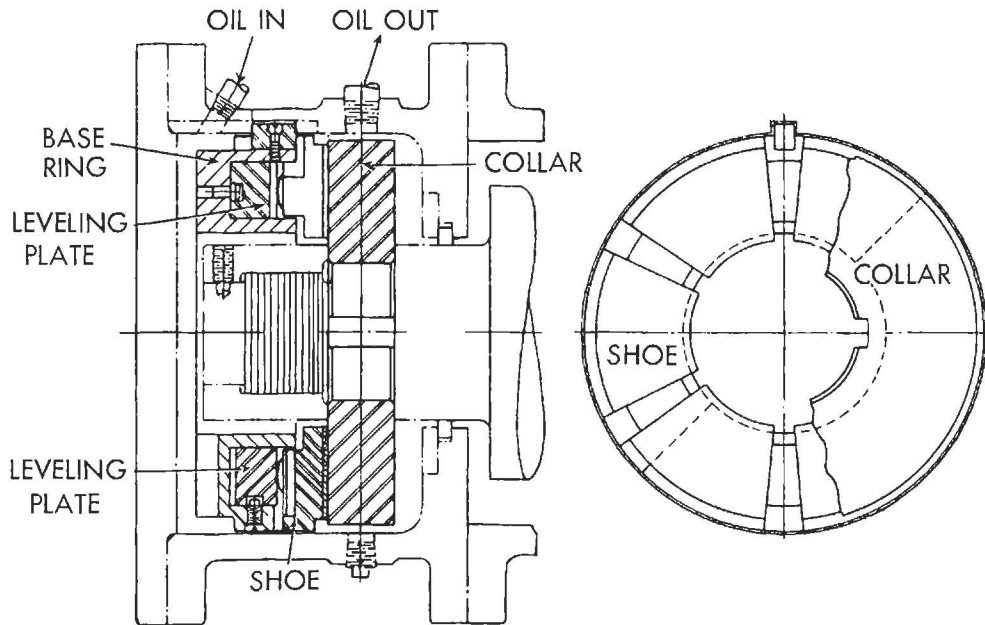

Figure 25
6-shoe one-way thrust with separate collar mounted on shaft end.

VERTICAL TURBINE THRUSTS

While the majority of turbine applications involve the use of a horizontal shaft, there are some pieces of apparatus, notably pump drives and forced-draft blowers, that are frequently arranged with the shaft vertical. Such cases require only a rearrangement of the same basic thrust bearing elements that have been described in connection with horizontally disposed apparatus.

There are three alternative operating conditions that may be encountered in vertical turbine drives. The principal thrust may be downward, with an occasional, lesser, upward reaction under certain operating conditions. On the other hand, the principal thrust may be upward, with minor downward thrust under certain conditions; say, at starting and stopping, etc. The third class is that in which the thrust is downward under all conditions of operation, in which case a single-element unidirectional thrust bearing will answer the requirements.

Bearings suitable for the three classes of service mentioned are illustrated in Figures 26, 27, and 28. The bearing shown in Figure 26 is arranged as a self-contained unit with an oil reservoir provided with a cooling coil to carry away the heat of oil friction. A guide bearing immediately above the thrust bearing is lubricated by employing the runner of the thrust bearing as a pump as indicated in the figure.

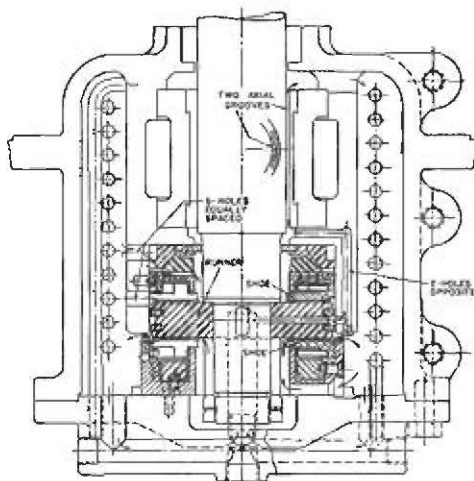

Figure 26
6-shoe and 3-shoe step-bearing for vertical unit where principal thrust is in downward direction.

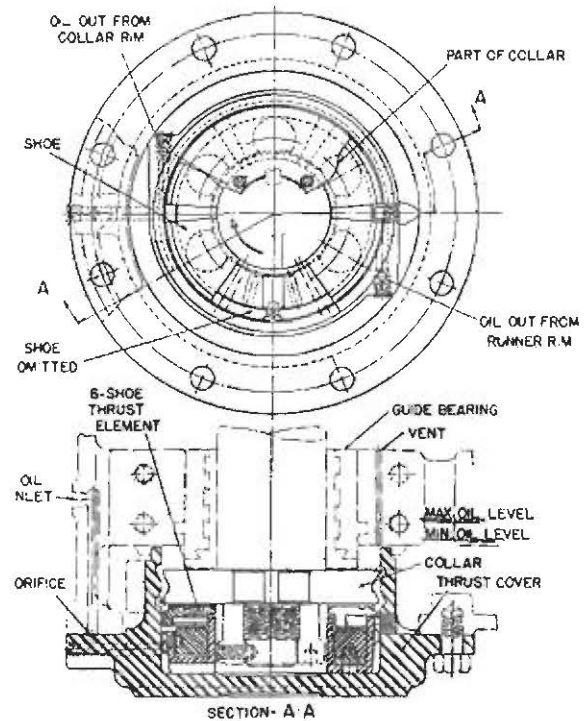

Figure 27
Arrangement of a vertical step-bearing for high speed with oil control feature in discharge from collar rim.

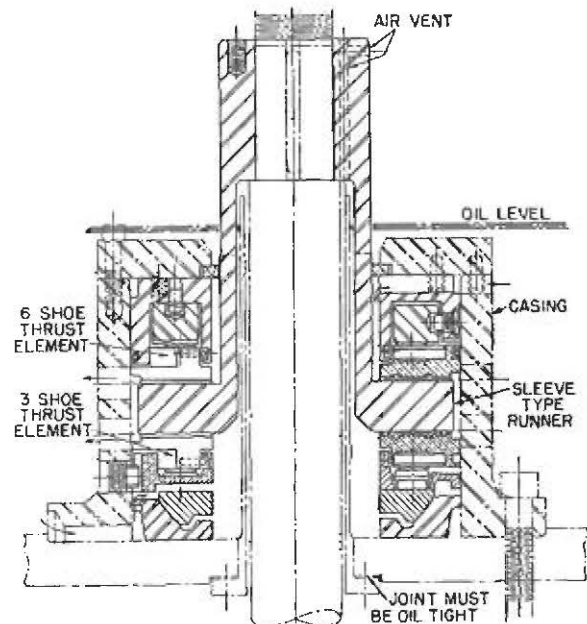
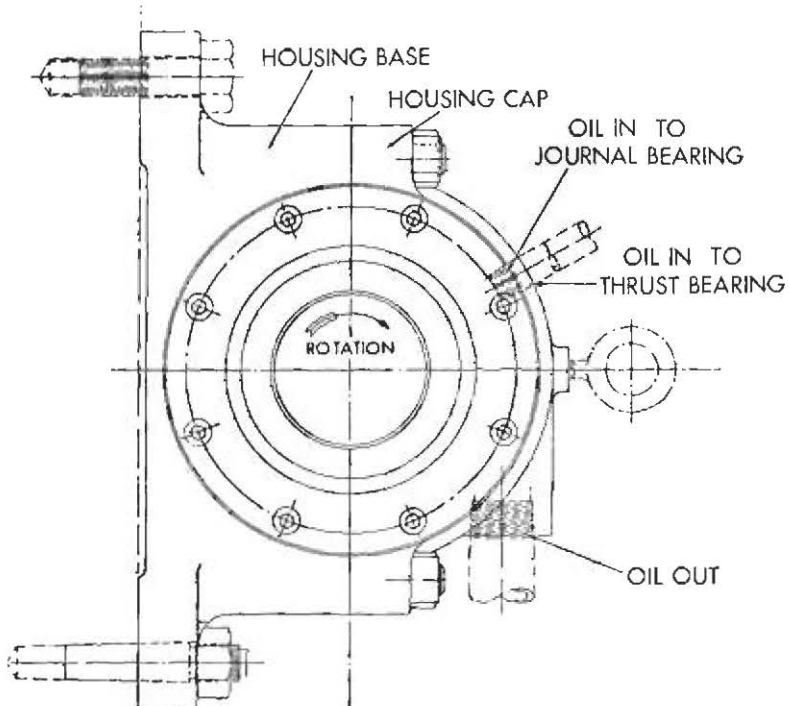

Figure 28
6-shoe and 3-shoe combination for vertical unit where major thrust is in upward direction.



The thrust bearing has a six-shoe element to take the principal thrust and a three-shoe element to take thrust in the opposite direction. Figure 28 shows a bearing enclosed in a casing which is completely immersed in an oil bath. Oil is admitted to the casing through apertures at top and bottom and is ejected, by the centrifugal pumping action of the runner, through holes in line with the runner edges, thus ensuring circulation of the oil around the cooling element in the reservoir. In this case also, a six-shoe element and a three-shoe element are used together.

Figure 27 shows a bearing of the step type having a single six-shoe element to take a uni-directional thrust. In this case it will be noted that the bearing housing is designed to embody the principle of the oil control ring and thus ensure minimum power loss. In bearings of this type the flow of lubricant must be fully established before the apparatus is started.

Obviously, numerous other combinations and variations are possible. These examples are shown only to indicate that practicable bearings can be provided to meet any structural or operating conditions that may be imposed by the character of the service intended. Our engineers are ready at all times to study and discuss special applications.

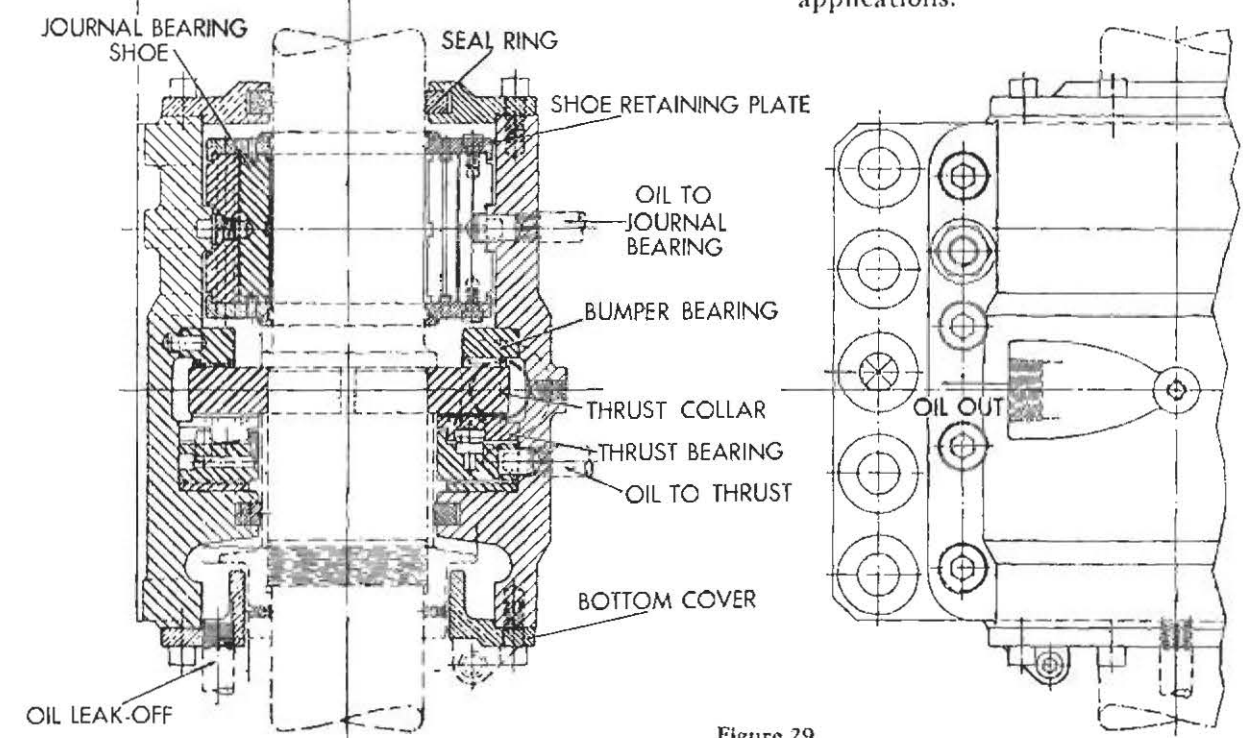

Figure 29
6-shoe vertical thrust with bumper bearing for reverse thrust and pivoted-shoe guide bearing.

LUBRICATION AND COOLING

Although the Kingsbury principle involves continuous self-renewal of the oil films between shoes and collar, the thickness of those films (and hence the safety of the bearing) depends on the operating conditions. These conditions include load per square inch of shoe area (which can be greater with large shoes than with small ones), and viscosity of the oil at running temperature. Temperature depends on speed and on the cooling means. At high speeds (turbines and blowers) there is also the possibility of power loss due to churning. This is minimized by using the oil control ring, pages 11 and 12.

Though the heating due to oil shear is small, it is a definite quantity which may be calculated. The cooling agent may be an attached external cooler. Or the bearing may be tied into a general lubricating system with central cooling. With vertical bearings, there may be a copper coil in the oil bath, through which cooling water flows.

The "internal" resistance to flow of oil through the bearing assembly itself is slight. The piping and the oil passages in the bearing should be designed to carry the required flow easily. If the oil pump develops high pressure, it may be necessary to restrict the flow to avert needless loss of power. Three to five pounds per square inch at the inlet is usually sufficient.

With oil cooling, the flow must be sufficient to carry off the heat generated by oil shear between shoes and collar. The operating instructions usually specify the viscosity and oil flow recommended. When the correct pressure and restrictions have been established, it is best to have the restrictions take the form of suitable drilled plugs in the oil line at inlet or outlet, or both, so that they cannot be inadvertently changed.

When an oil control ring is used, only the inlet is restricted, the outlet being left wholly free. The top discharge is then tangential, like

that from a centrifugal pump, into a large drain passage.

Horizontal Bearings

Horizontal bearings usually run in sealed cavities through which oil flows and escapes at the top above the thrust collar. The housing must be designed with reference to the entry and discharge of the oil stream. For horizontal shafts the points of entry (on each side of the collar) are usually in the lower housing, and are so placed as to lead directly to oil passages in the six-shoe base ring or three-shoe leveling washer.

Vertical Bearings

Most vertical bearings run in a bath of oil, which is kept from the shaft by a fixed oil-retaining tube secured to the housing at its base with an oil-tight joint. The tube rises above the highest level of the oil in the bath. The runner is bored to clear the tube by a space sufficient to avoid objectionable oil foaming at the intended speed.

Where only downward loads and ordinary speeds are expected (such as in pumps and generators), very simple arrangements are sufficient. For such bearings, in medium to large sizes, the usual cooling means is a water coil submerged in a large oil pot surrounding the bearing. Baffles should be used to ensure oil movement across the coil. An alternative is to circulate the oil in and out, and cool it outside, where any leak in the cooler can more readily be seen and repaired. Where the oil is to be cooled outside the housing, the required flow is specified in the instructions which accompany each order.

For high-speed vertical bearings (as for vertical turbine-driven auxiliaries on shipboard), arrangements similar to the oil control ring should be worked out. As they are somewhat special, we should be consulted.

Symbols for Standardized Designs









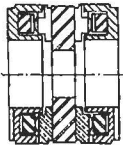

Kingsbury Thrust Bearings are built in a great variety of types and sizes. They may be regarded as a unique system of elements built around moving films of oil, rather than as specific articles of manufacture. Certain standardized

components are used in various groupings, with lubrication and housing to suit.

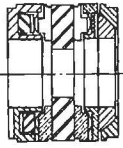
Designs, past or present, sufficiently established to carry symbols are here listed. Current standards should be used wherever possible.

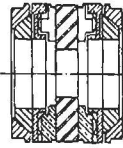



Equalizing Types, Horizontal and Vertical Elements Only

NOTE: "H" as part of symbol means that separate collar is furnished by us. "6" or "3" means shoes on one side only of collar. "6 x 6," etc., means shoes on both sides. "J" and "B" base rings are usually split; "N" base rings are always solid.

| Bearing Symbol (See Note) | Horiz. or Vert. Shaft | No. of Shoes (See Note) | Usual Size Range | Description | | |
|------------------------------|-----------------------------|-------------------------------|------------------------|---|-----|--|
| JHJ | H | 6 x 6 | 5-17 |  | JHJ |  JHJ Elements |
| JH | H | 6 | 5-17 |  | JH | |
| JJ | H | 6 x 6 | 5-17 |  | JJ | |
| J | H | 6 | 5-17 |  | J | |
| BHB | H | 6 x 6 | 5-45 | | | <p>B base is same as for J series except thinner.</p> |
| BH | H | 6 | 5-45 | | | |
| BB | H | 6 x 6 | 5-45 | | | |
| B | H | 6 | 5-45 | | | |
| JHN | H | 6 x 3 | 5-17 |  | JHN |  JHN Elements |
| JN | H | 6 x 3 | 5-17 |  | JN | |
| BHN | H | 6 x 3 | 5-17 | | | |
| BN | H | 6 x 3 | 5-17 | | | |
| NHN | H | 3 x 3 | 5-17 |  | NHN |  NHN Elements (Compare JHN) |
| NH | H | 3 | 5-17 |  | NH | |
| NN | H | 3 x 3 | 5-17 |  | NN | |
| N | H | 3 | 5-17 |  | N | |

Symbols for Standardized Designs

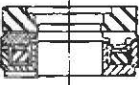
Equalizing Types, Elements Only
(continued)

| Bearing Symbol (See Note) | Horiz. or Vert. Shaft | No. of Shoes (See Note) | Usual Size Range | Description | |
|------------------------------|-----------------------------|-------------------------------|------------------------|---|--|
| KV | V | 6 | 5-17 |  KV | |
| LV | V | 3 | 5-17 | | LV  |
| JV | V | 6 | 5-17 |  JV |  |
| BV | V | 6 | 5-17 | BV is like JV but thinner base ring. | |
| NV | V | 3 | 5-17 | |  NV |
| KBV | V | 6 | 19-45 |  KBV | |

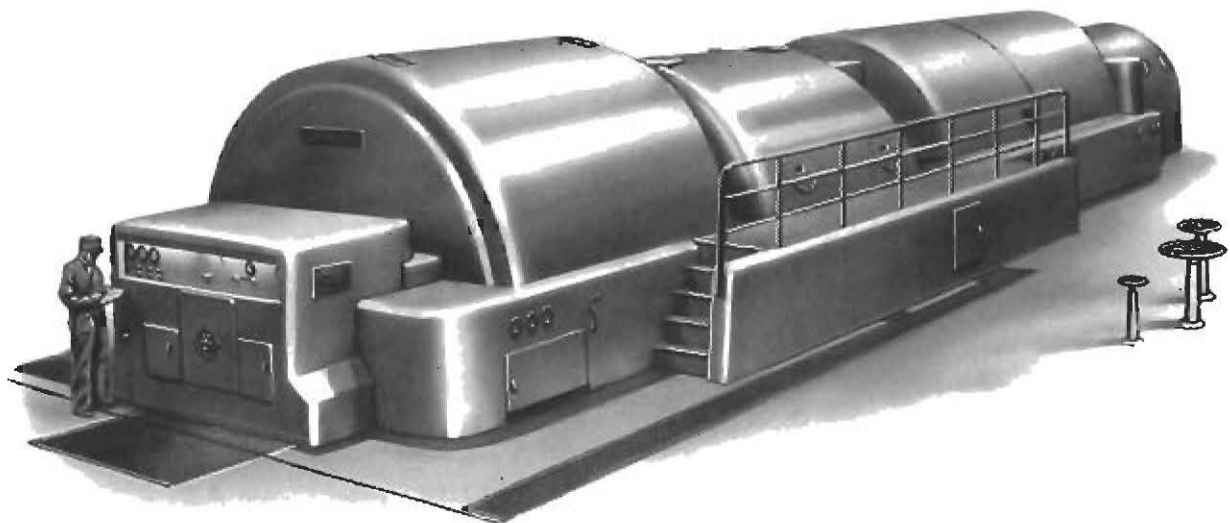

100,000-kw, 3600-rpm tandem compound reheat steam turbine installed in Minnesota.
Steam conditions: 1450 psig 1000/1000° F. 1½" abs. exhaust pressure.

Photo, courtesy Allis Chalmers, Milwaukee, Wis.

JOURNAL BEARINGS

Kingsbury Journal Bearings are designed in accordance with the same physical laws which dictate the behavior of the oil films in Kingsbury Thrust Bearings. As is in fact the case with all successful bearings of this type, sufficient oil is supplied not only to insure a self-renewing film between the journal and bearing surfaces, but also to carry away the heat of oil shear and any heat that may be transmitted to the bearing from adjacent hot surfaces.

Separate journal bearings are always, and those used in conjunction with thrust bearings are frequently, made of the self-aligning type. This characteristic is obtained by making the

axial dimension of the supporting surface in the housing quite small with respect to the axial length of the bearing surface, so that within small limits the bearing can adjust itself to accommodate misalignment of the housing and shaft.

A small bearing of this type is illustrated in Fig. 30. It is designed for pump service and is mounted in a bracket-type housing which is bolted to the pump body. It receives lubricant either from an outside source or from the combined thrust-and-journal bearing at the other end.

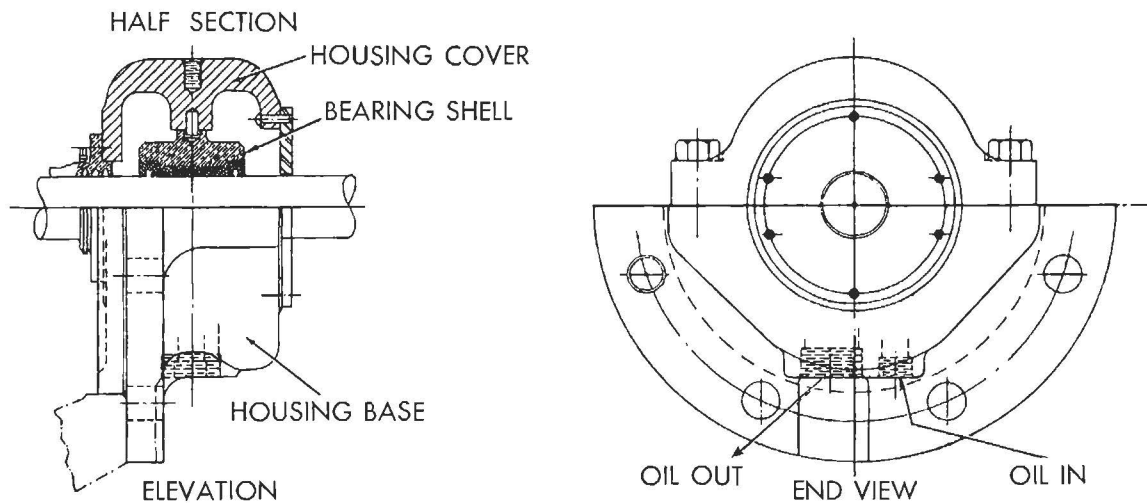

Figure 30
Typical small shell-type journal bearing in bracket bolted to the end of the apparatus housing.

Segmental Pivoted-Shoe Type Journal Bearings

For service at very high speeds and in applications in which shaft-whip is a possible source of trouble, Kingsbury has developed a segmental pivoted-shoe type of bearing which appears to provide the answer to some of the special problems encountered where very high speeds are required.

In this design the bearing surface is divided into segments, or "shoes," usually 4 or 5 depend-

ing on the journal size. These segments are held in a circumferential cage called an "aligning ring," the ends of which are closed by "shoe retaining plates." The retaining plates are drilled to receive "shoe stop pins" which locate the shoes circumferentially.

The shoes are machined so that their "backs," or outer surfaces, touch the aligning ring only along a narrow axial surface, about which the shoe can pivot by an amount determined by the radial clearance.

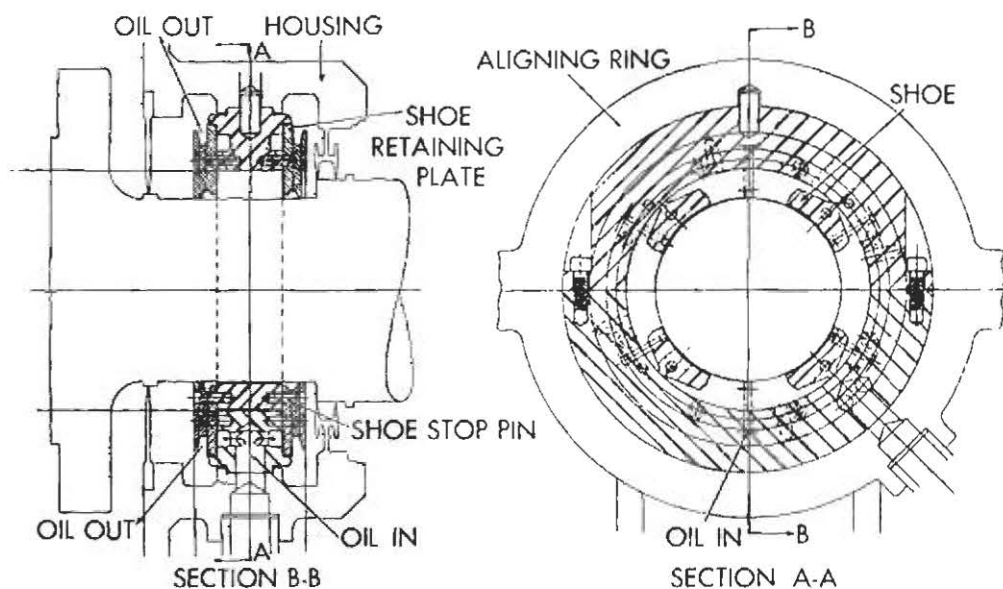

Figure 31
Journal bearing of the pivoted-
shoe type with four shoes.

An ample supply of oil is fed into the spaces between the shoes and as soon as rotation starts a film of oil is drawn in between the journal and each of the shoes, the film being thicker at the entering edge. Thus is established the automatically self-renewing "wedge-shaped film of oil" between each shoe and the journal, which is the distinguishing characteristic of Kingsbury bearing design.

Since the shoes are equally spaced around the journal, and each has between it and the journal a supporting and cushioning film of oil,

it can readily be seen that this arrangement is highly effective in damping out any tendency toward whip or vibration.

These bearings are used both as separate journal bearings and in combination with a suitable type of Kingsbury Thrust Bearing, and in vertical as well as horizontal applications. Figures 31 and 32 show typical separate journal bearing examples, while Figure 29 shows a vertical unidirectional equalizing thrust bearing with a pivoted-shoe journal bearing.

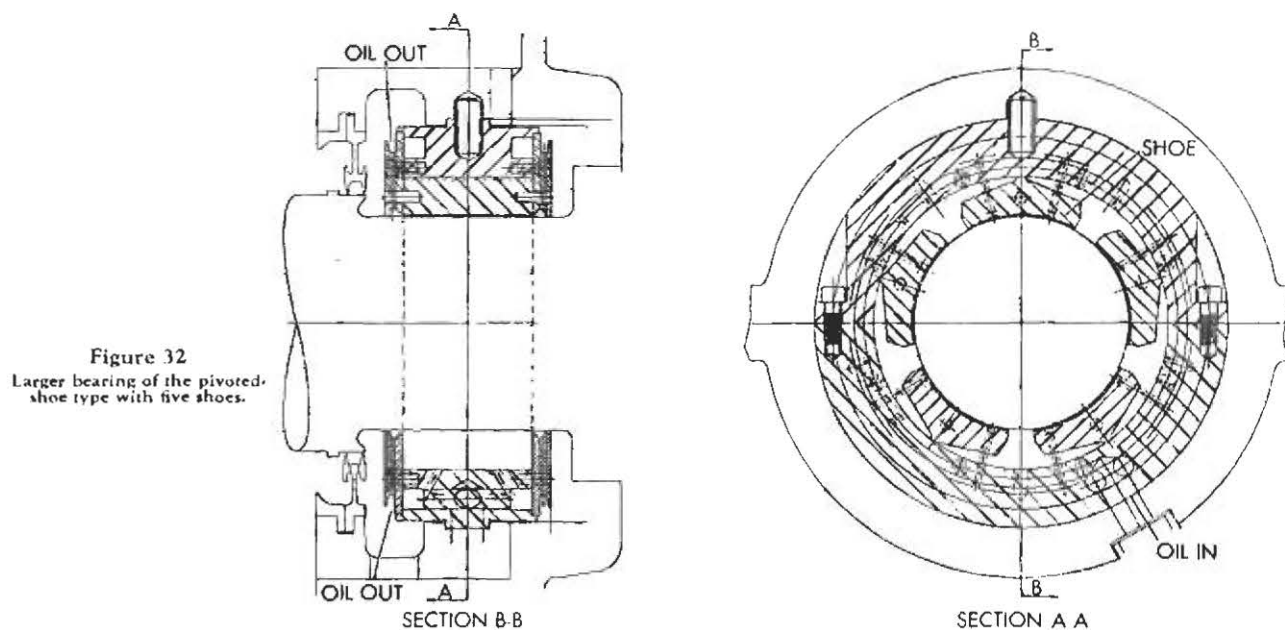

Figure 32
Larger bearing of the pivoted-
shoe type with five shoes.

SPARE PARTS

A Kingsbury Bearing correctly chosen, properly aligned and supplied with clean oil, is practically indestructible for the life of the ship. However, spare parts are customarily provided as a matter of insurance.

For marine machinery, American Bureau of Shipping rules will usually determine what spare parts are required. These regularly include thrust

shoes, occasionally thrust collars, also journal bearing shells and cooler parts where fitted.

For other applications, it is usually sufficient to stock thrust shoes, and thrust collars or runners.

The other parts of the bearing practically never need replacement. Therefore, there is no need to carry *complete* bearings as spares.

DATA NEEDED WITH INQUIRIES

In order that we may be able to cooperate intelligently in the selection of the proper Kingsbury bearing for a new application, we should receive full information regarding the expected conditions of operation.

Specifically, we should have at least the answers to the following:

- (A) Is shaft horizontal or vertical?
- (B) What are thrust loads, normal and maximum?
- (C) What reverse thrust is expected, if any?
- (D) What are the rpm, normal and maximum?

- (E) What is shaft diameter in way of bearing?
- (F) Will thrust collar be integral with shaft or separate?
- (G) Are solid or split base rings desired (6 or 8 shoe only)?
- (H) What are characteristics of lubricant to be supplied and what is expected inlet temperature?
- (J) What is journal bearing load (when applicable)?

In addition, the kind of service should be stated, the general arrangement of the machine should be sketched or described, and any pertinent space limitations indicated.

STANDARD GUARANTEE

Any bearing or part furnished by us, which shall prove defective in design, material or workmanship within one year after installation and test, will be replaced without charge f.o.b. Philadelphia, if returned to our factory. This period is, however, limited to a maximum of two years from the date of shipment from the fac-

tory. No allowance will be made for labor or other expense in connection therewith unless authorized in writing by an officer of the Company.

For oil coolers and cooling coils, in accordance with usual trade practice, there is no specific guarantee period.

