

KINGSBURY BEARINGS

**for
Centrifugal Pumps**

Bulletin P

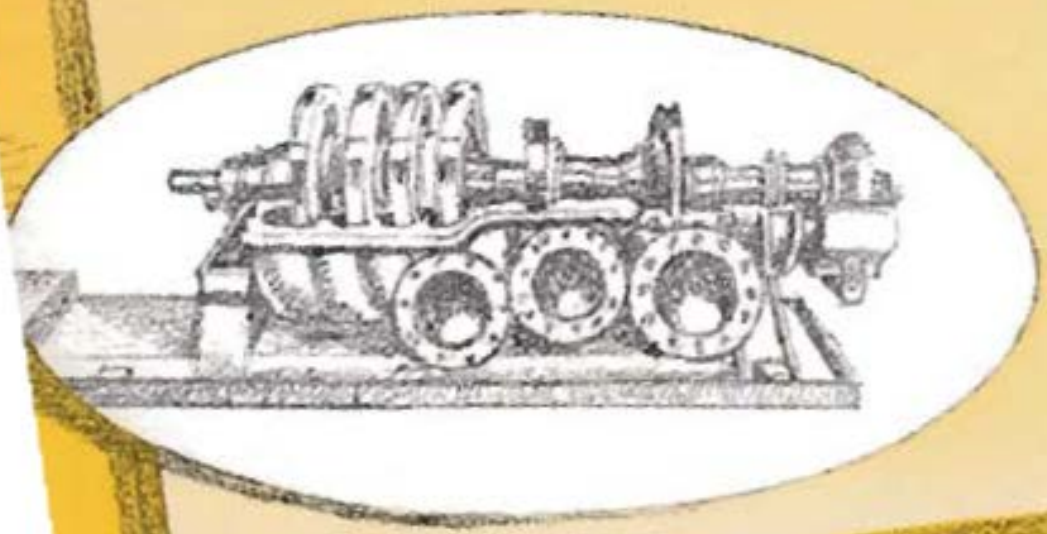

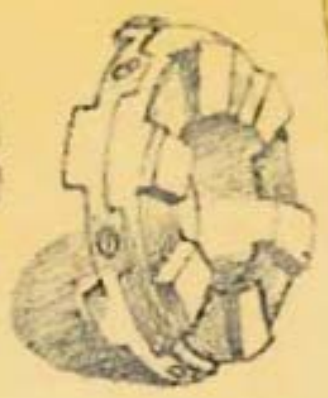
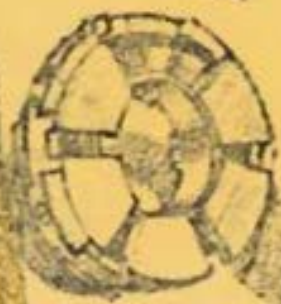
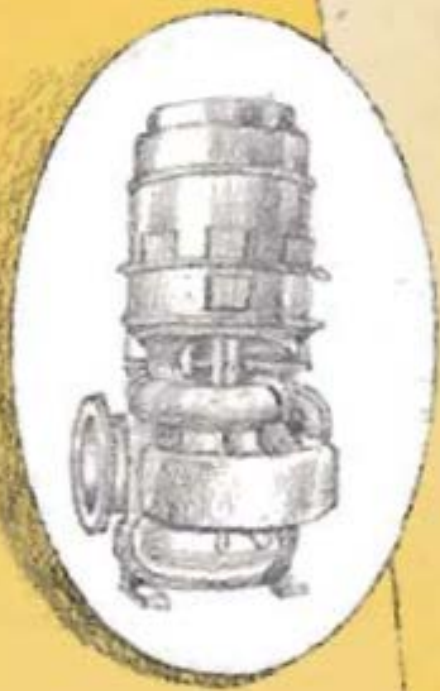
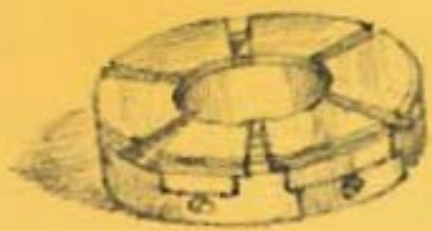

KINGSBURY
Thrust and Journal
BEARINGS
for
CENTRIFUGAL PUMPS

BULLETIN P



KINGSBURY MACHINE WORKS, INC.

Main Office and Works

FRANKFORD, PHILADELPHIA 24, PA.

CONTENTS

Foreword	5
The Kingsbury Principle	6
History of Development in America	6
Centrifugal Pump Thrust Bearings	7
Horizontal Bearing Units, Styles CH and C	8
Thrust Elements	9
Journal Bearings	9
Lubrication	10
Oil Circulation	10
Cooling Arrangements	12
Oil Supply to Separate Journal Bearings	13
Special Starting and Running Conditions	14
Other Special Features	14
Shaft Forms Commonly Used	14
Style "C" Separate Journal Bearings	15
Special Thrust Bearing for High Speeds (Horizontal)	15
Thrust Bearings for Vertical-Shaft Pumps	16
Vertical Mounting Arrangements	18
Separate Vertical Guide Bearings	19
Data Needed With Inquiries	20
Standard Guarantee	20

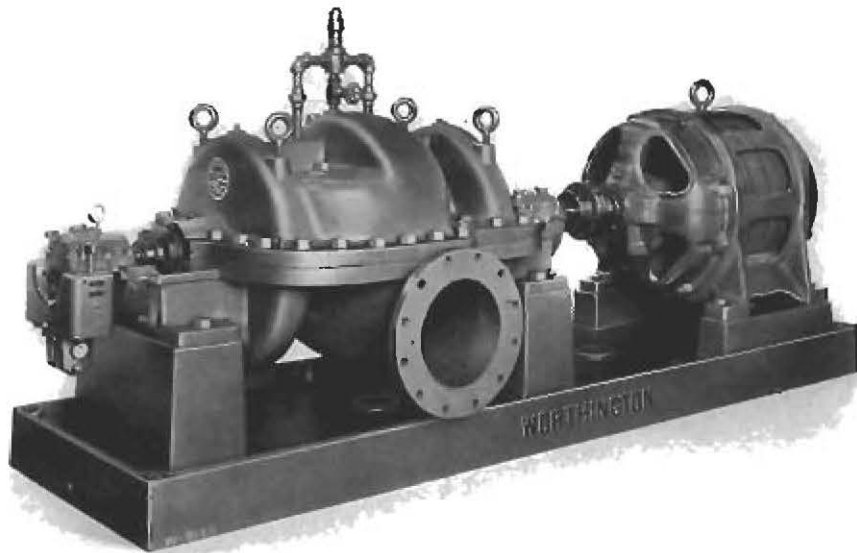

Worthington Three Stage Centrifugal Volute Hotwell Pump fitted with Kingsbury Style "CH" Thrust Bearing.

Photo Courtesy Worthington Pump & Machinery Corp.

FOREWORD

This Bulletin is devoted primarily to Kingsbury Bearings for centrifugal pump service. Specific types of thrust bearings and journal bearings are described, for horizontal and vertical shafts, with notes on their application to various kinds of pumping units.

Important examples are boiler feed pumps, booster pumps, hot oil pumps and pipe line pumps, each representing very responsible power plant or industrial service. For vertical pumps the thrust bearings are usually installed in the driving motor or turbine. Deep-well pumps and condenser circulating pumps are types with which we are frequently concerned. Vertical electric generators, in medium sizes, use the same bearing arrangements as pump motors.

Kingsbury Spherical Bearings, applied to vertical shafts, combine thrust and radial functions in a single set of elements. Several installations are shown.

Most of the bearings here described have self-contained, automatic lubrication, obtained with no added moving parts.

Information on dredge pump applications will be furnished on request; the bearing sizes are larger than those described in this Bulletin.

Other booklets, available on request, give more detailed information on the principles and designs of Kingsbury bearings, and include data on mounting dimensions, load capacities, and weights of horizontal and vertical types.

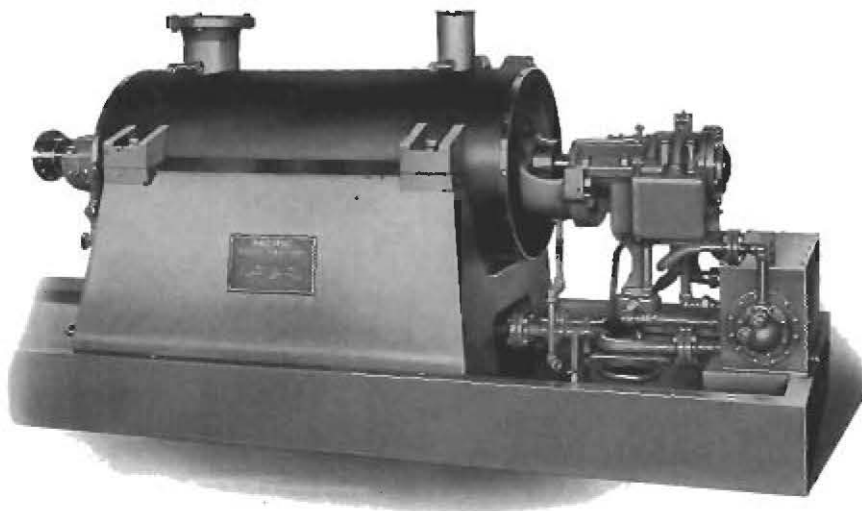

"Pacific" 6-inch Ten Stage High Pressure Boiler Feed Pump
equipped with Kingsbury Thrust Bearing.

Photo Courtesy Pacific Pumps, Inc.

Horizontal Bearing Units, Styles CH and C

Style CH Thrust Bearings are designed for horizontal centrifugal pumps, especially multi-stage boiler feed and booster pumps, circulating pumps, heater pumps, etc., and for the smaller horizontal water turbines. Standard sizes run from 4 to 9 inches nominal diameter of thrust collar, carrying roughly from 1,000 to 16,000 pounds thrust load in either direction. Their ability to run indefinitely without wear makes them especially suited for the most responsible duty, as in central stations, industrial plants, and on shipboard.

The standard bearings here described have a housing flange for direct attachment to the pump body; and they include the journal bearing for that end of the pump. Both thrust and journal bearings are self-aligning in most cases.

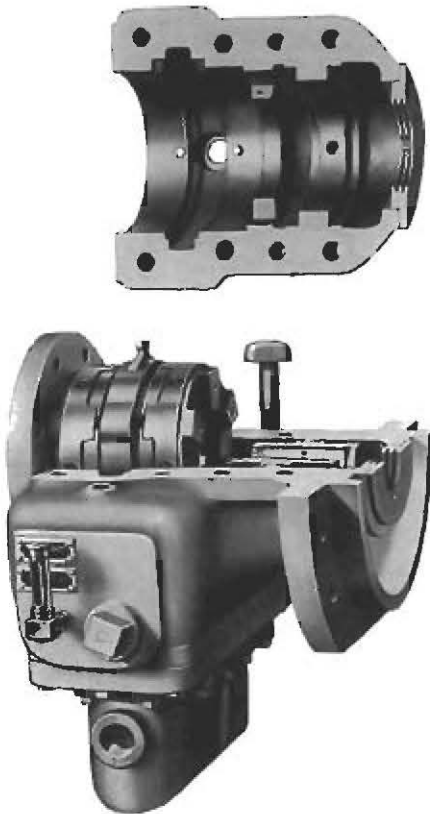

Figure 8
Standard Style CH Thrust Bearing with built-in journal bearing and attached cooler, for boiler feed pumps. Oil circulator surrounds thrust collar.

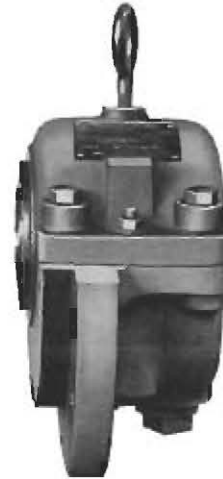

Figure 9
View of Style C Separate Journal Bearing.

The separate Style C Journal Bearings, Figures 9 and 11, are designed for the inboard or coupling end of the pump. They correspond in general to the journal bearing built into the thrust housing, and are similarly mounted.

Unless otherwise specified, the entire CH bearing unit is self-contained as regards oil circulation and cooling. The oil is circulated internally by an extremely simple device, consisting of a specially-formed stationary ring called a "circulator". This surrounds the thrust collar and acts as a viscosity pump. There are no moving parts except the shaft and collar. Start of flow is practically instantaneous, to both thrust elements, to the journal bearing and to the oil cooler. The same circulator supplies oil also to the Style C journal bearing.

A recent improvement insures the ability of the oil circulator to deliver oil to a remote journal bearing at very low speeds. This is important for steam turbine-driven standby units, where the need may arise to keep the unit in continuous readiness by turning it over slowly.

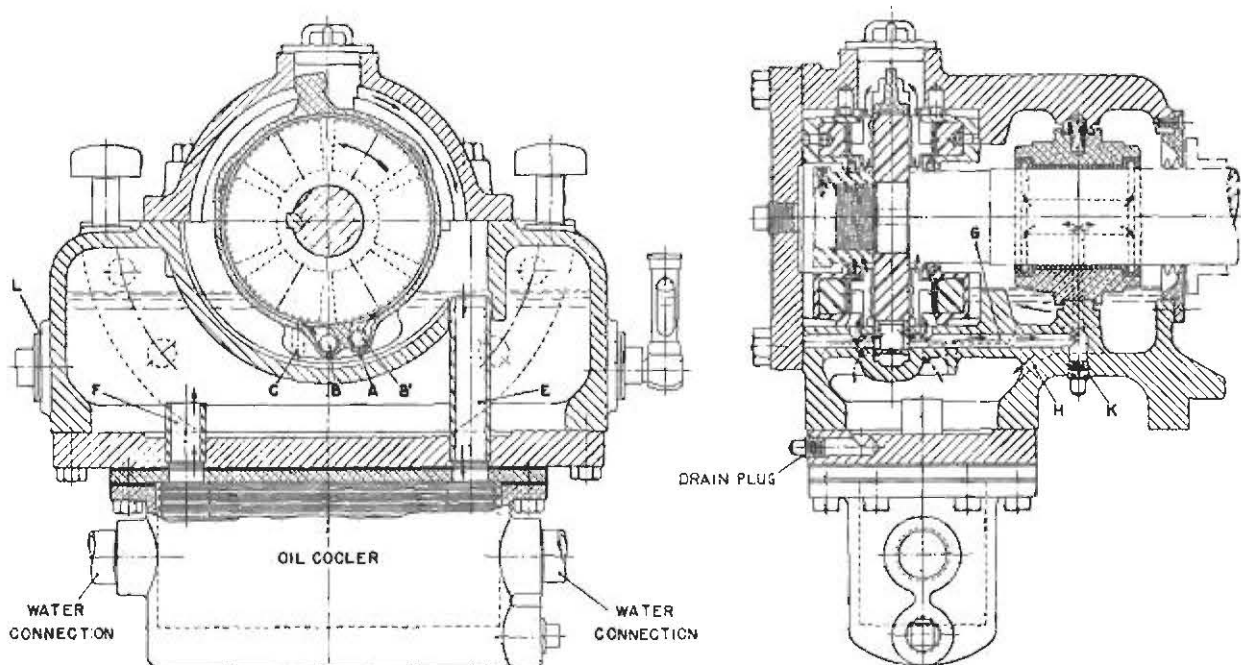

Figure 10
Transverse and longitudinal sections through a standard Style CH Thrust and Journal Bearing showing the circulator and its parts, with arrows to indicate the direction of oil flow.

Thrust Elements

In sizes 5 to 9 inches, standard CH bearings have 6 shoes each side of the thrust collar: 4-inch bearings have 4 shoes. In both 6-shoe and 4-shoe bearings, the loads are equalized among the shoes by the leveling plates shown in developed diagram in Figure 5. The shoes have hardened steel buttons set into their backs, which bear on the hardened surfaces of the "upper" leveling plates.

The base rings containing the leveling plates are split to permit radial assembling.

The collar is usually a separate piece, keyed on the shaft and firmly clamped against a shoulder by a large nut. It can, however, be forged in one piece with the shaft, if preferred.

By lifting the top cover, the shoes of any CH bearing may be removed and inspected; also the split base rings. The collar may be drawn off the shaft after the end cover is removed.

Journal Bearing

The built-in journal bearing of a CH unit is self-aligning. This feature assures a uniform end-to-end distribution of load. Like the thrust element, the journal element receives oil under pressure; and the grooving is such as to preclude entry of bubbles which might reduce the load-carrying capacity. The journal bearing is also cooled—not merely lubricated—by causing oil to flow through it in a constant stream. Because of these features, a short bearing is ample for the required duty.

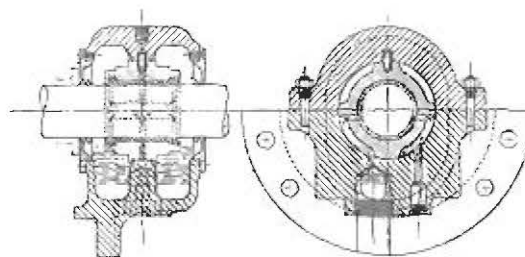

Figure 11
Sectional views of Style C Journal Bearing.

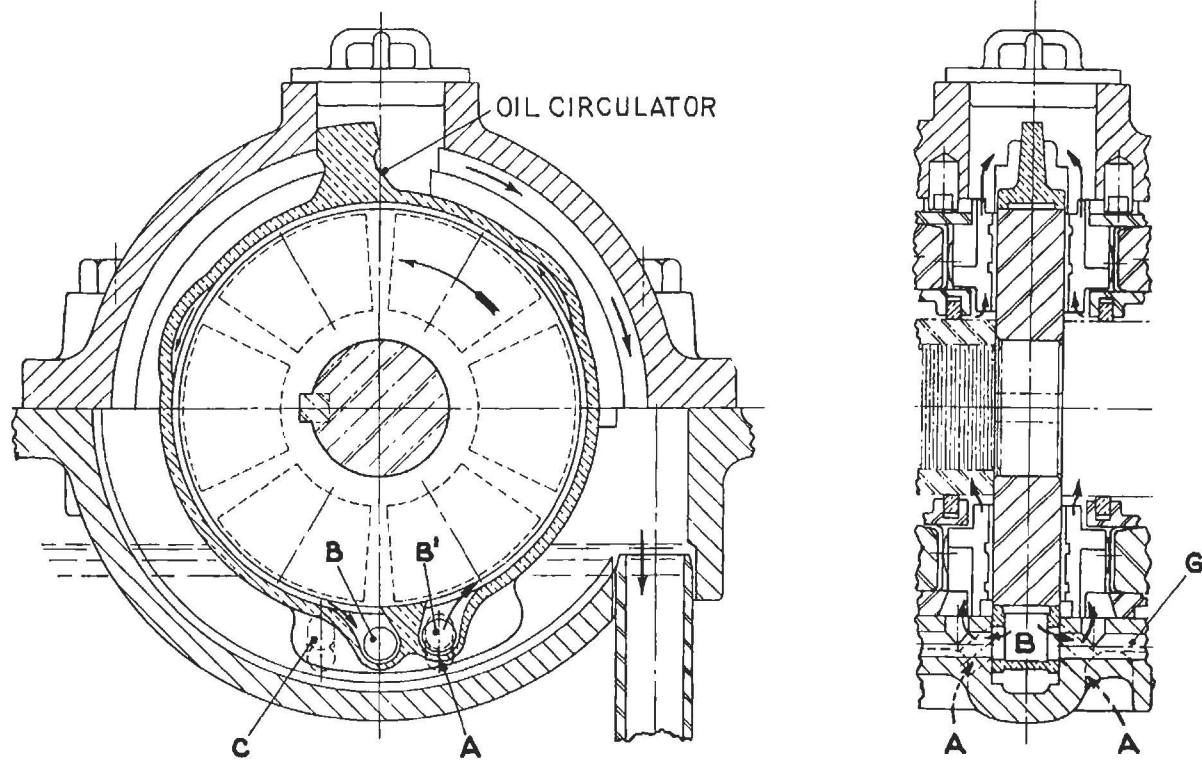

Figure 12
Enlarged part sections from Figure 10 showing circulator oil inlets and outlets.

Lubrication

When running, the space containing the thrust collar, shoes, leveling plates and base rings is filled with oil, which is circulated through the working space and through the cooler as described elsewhere. Entering the space between the two lowest shoes, the oil flows toward the shaft as shown by the arrows in Figures 10 and 12; then spreads around the shaft and moves radially outward through the spaces between the other shoes. Thus the heated oil in the films between the shoes and collar is immediately replaced by the incoming stream of cooled oil.

As the heated oil reaches the collar rim, it leaves the working space by an outlet at the top, and returns to the cooler.

Since the working space (or "thrust cavity") is full of oil while running, no foaming can occur to reduce the load-carrying capacity of the oil films. This applies not only to the thrust bearing proper, but also to the journal bearing.

Oil Circulation

Oil is circulated through both thrust and built-in journal bearings and the cooler, and may be supplied also to the other (inboard) journal bearing, by means of the "circulator" (Figure 12) surrounding the thrust collar. The circulator is a bronze ring, loosely fitting the thrust collar but not turning with it, and having a shallow groove extending almost all around its bore. The groove is interrupted by a dam at the bottom, between two ports, *B, B'* (see Figure 12). The bottom of the circulator is a sliding fit in an enlarged recess machined in the housing. Both the circulator and the thrust collar dip into the oil. Ports *B, B'* register with holes drilled in the housing for passage of oil.

The effect of this arrangement is to draw oil from the reservoir when the collar turns, into the groove in the circulator bore, then (by adhesion to the collar) around to the *other* port at the bottom of the circulator, where it meets the dam.

It is there scraped off, and forced, by the pressure of oil behind it, into the thrust bearing cavity and to the journal bearing or bearings. As explained below, the circulator is so arranged that this pumping action operates in either direction of shaft rotation. Due to the cling of the oil to the collar, a pressure of several pounds per square inch is built up.

With left-hand rotation, as in Figure 12, the stop lug at the top of the circulator holds it in the position shown. Right-hand port *B'*, in the circulator, then registers with entry ports *AA* in the housing. On meeting the dam, the oil is pushed out through port *B* into passage *G*. Part goes immediately upward into the thrust cavity on both sides of the collar. Filling the cavity, it issues at the top, where a window shows the flow. It then passes into the space surrounding the circulator, and runs down into the cooler by passage *E*. From there it returns to the reservoir at *F*.

Meanwhile, part of the oil discharged from the circulator flows by passage *G* to another passage (dotted) leading to a recess in one side of the journal bearing shell. Filling this recess, it flows through circular grooves at both ends of the shell, around to a similar recess on the other side, leading back to the reservoir by the (dotted) drain passage *H*.

The grooves at both ends of the journal bearing shell are filled with oil under pressure from the side recess, thus preventing entry of air and resultant loss of load capacity due to foam.

If the direction of rotation is *reversed*, oil drag turns the circulator clockwise till the top lug is again halted, this time with right-hand port *B'* registering with passage *G* in the housing, and left-hand port *B* registering with entry port *C*. Thus the functions of the inlet and outlet ports are reversed, but oil is still pumped into passage *G*. Extended pads, forming part of the circulator, cover up ports *C C* or *A A*, whichever are not being used.

If the separate or inboard journal bearing also is to be oiled from the circulator, the connection is made at *K*. In that case a large gravity return pipe is used. The return connection is made at *L* on either side, the oil gauge being mounted on the other side.

Where the shaft passes through the housing, a suitable end closure prevents escape of oil and entry of dirt. If there is danger of water entering, a special thrower is added.

Any condensate water that might collect at the bottom of the reservoir is easily drained off by opening a special plug. See Figures 10 and 13.

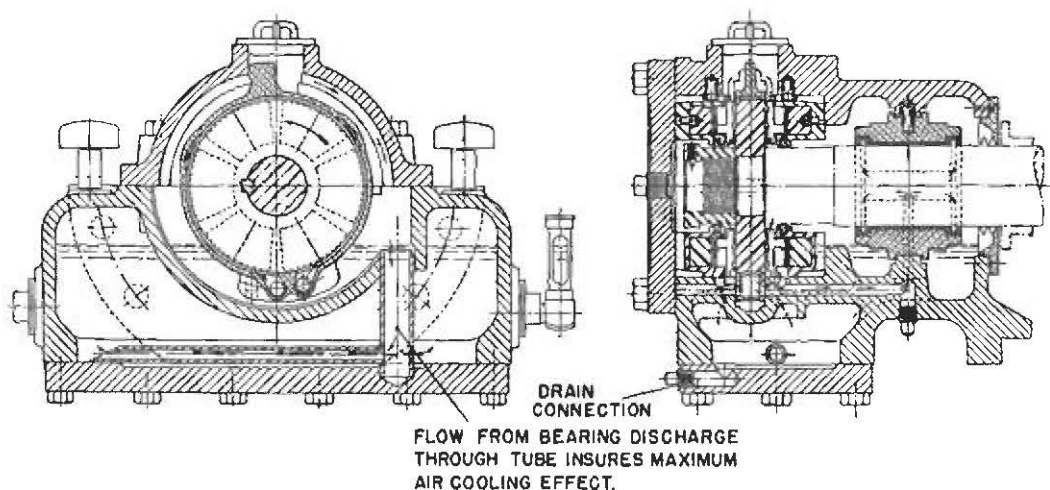

Figure 13
Style CH bearing arranged without cooler (see text, page 12).

Cooling Arrangements

The "Harrison" cooler is standard, and in regular applications is directly attached to the bearing housing.

This cooler is of the "plate" type, with the oil circulated through hollow "plates" surrounded by the cooling water. The outer case contains a renewable zinc rod electrode to protect the "plates" from corrosion. The case is readily lowered for the purpose of cleaning the "plates" on the water side. See photograph, Figure 14. If necessary, this can be done without stopping the pump.

Since only clean filtered oil is supplied to the bearing, the interior of the "plates" should rarely if ever need cleaning. However, in case water or dirt should become mixed with the oil, cleaning of the interior is easily accomplished.

The required size of cooler depends on the power loss due to oil friction. This is governed partly by the load, partly by the running speed. Coolers can be provided to suit any speed within commercial range. For very low speeds, the bearing may run air-cooled. For speeds exceeding 4500 rpm in the 4-inch size, and 3600 rpm in other sizes, it is best to employ a separately mounted cooler (or coolers) of higher capacity. These are commonly of tubular type, attached to the pump foundation and piped to the thrust bearing and to the water supply. See Figure 17. We should be consulted as to the proper selection of coolers.

When desired, these bearings can be furnished without coolers, for connection to a general oil circulating system. See Figure 19. In such cases the "circulator" shown in Figure 19 is still retained in order to ensure proper flow of oil through the internal parts.

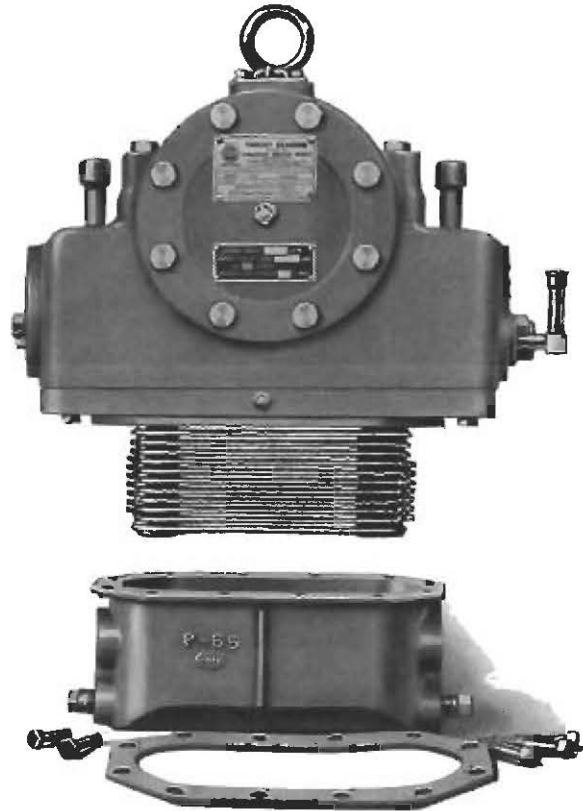

Figure 14
Photograph of Style CH bearing with cooler shell lowered for cleaning of water spaces.

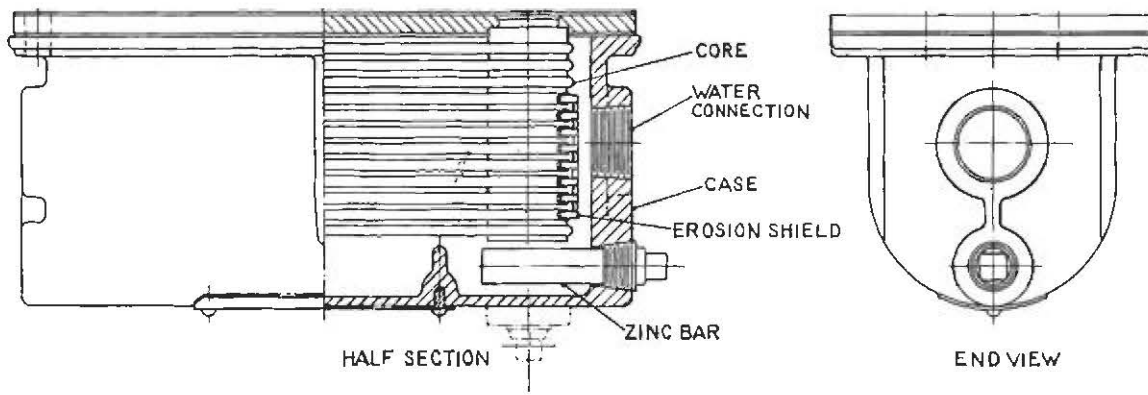

Figure 15
Part section of Harrison cooler showing zinc plug to prevent electrolytic action.

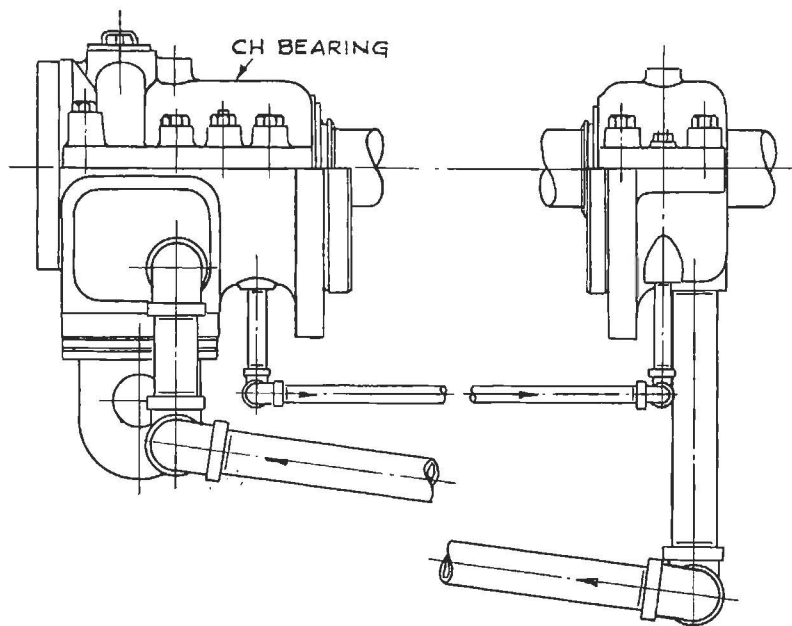

Figure 16
Arrangement of supply and return lines for lubrication of
outboard journal bearing from thrust bearing.

Oil Supply to Separate Journal Bearings

When oil is piped from the thrust bearing to the inboard journal bearing, the usual arrangement of piping is shown in Figure 16. The return pipe from the journal bearing should go straight down a sufficient distance to permit a slight upward slope to the thrust bearing. See Figure 16. The purpose of this is to carry air bubbles to the thrust bearing, where they can be vented.

As the gravity head on the returning oil stream is slight, the return pipe must be of liberal size.

In case the oil has to flow some distance, as might be the case for *two* separate journal bearings, or if the pipes are exposed to cold, two separate return systems are used jointly instead of one.

In the first system, a pipe takes oil directly from side outlets coming from the journal bearing shells; the oil reaching those outlets is still under appreciable pressure that can be utilized for returning the oil. The second system consists of a return line connected to the sump in each of the journal bearing housings. It receives only the oil escaping from the ends of

the journal bearing shells. This second return line (called the "leakage return line") should be of liberal size. Both return lines should follow the rule above mentioned, i.e., of going straight down, and then upward on an easy slope to the thrust bearing.

All piping should be protected against such cold as might render the oil flow sluggish. Both supply and return pipes should be carried well below the oil level in the thrust bearing. Flow conditions in general should be carefully checked to make sure that there can be no backing up of pressure.

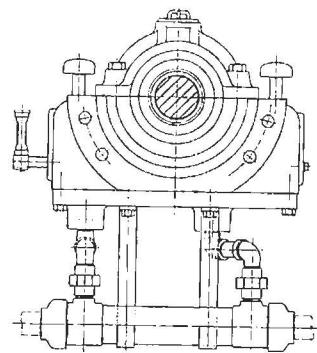

Figure 17
Style CH bearing with external oil cooler.

Special Starting and Running Conditions

Style CH bearings require no special provision for starting "across the line" with a.c. motors. This is because the oil pumping action starts so quickly that the shoes are already lubricated before the load is felt.

Another condition, however, is the slow idling sometimes given turbine-driven pumps, to keep the turbine warm for a quick start. Some customers prefer to give the journal bearings of such pumps the additional protection of an oil ring to assist lubrication at idling speeds. We can furnish an oil ring for that purpose without otherwise altering the design. The ring is shrouded in such a way as to prevent it from making undue foam in the bath, at turbine speeds, while still being effective at idling speeds.

Other Special Features

If desired, the shaft may be extended through the end cover, which is then of special design. Figure 19 shows such a design. Thus the extended shaft may drive an oil pump supplying the entire turbine-pump unit. In that case the oil circulator is still required, in order to deliver oil to the internal parts. Or the extended shaft may drive a booster pump, in which case the thrust bearing of each pump has its own self-contained lubrication system.

Although the attached flange from bearing to pump has a standard radius and thickness for each bearing size, special flange sizes can be provided at additional cost. All departures from standards should be avoided, if possible, as they entail extra cost and sometimes considerable delay.

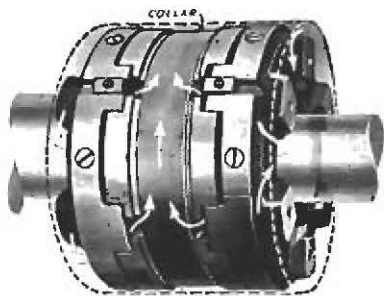

Figure 18
Horizontal double six-shoe thrust bearing assembled.

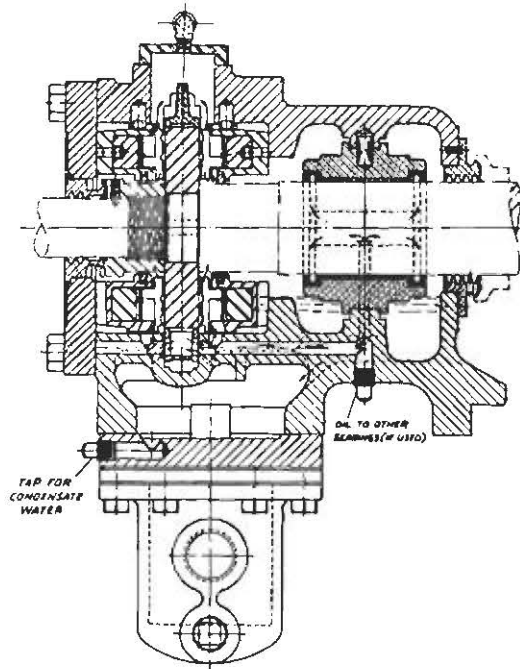

Figure 19
Assembly of Style CH bearing with shaft extended through cover for attachment of oil pump or other ancillary equipment.

Shaft Forms Commonly Used

Shafts used with standard CH thrust bearings have separate thrust collars. Separate collars are preferable, as they reduce the cost of the shaft.

In designing the shaft, it should be noted that the diameter and thickness of the thrust collar, and details of the shoes and bases, are fixed by our standards. Deviations from these standards make the mounting more or less special. Other shaft details may be varied within certain limits. Thus, a choice may be made of journal sizes for each collar diameter.

For actual dimensions of journals and collars available for the various standard bearings refer to tabulated data in the catalog covering bearings of this type, which will be furnished upon request.

By utilizing this freedom of choice regarding shaft sizes, the collar size (and hence the size of the mounting) can be selected to suit the thrust load and the dimensions of the pump.

Style "C" Separate Journal Bearing

Style "C" Journal Bearings (Figures 9 and 11) are intended for the inboard ends of the pump shafts. They are similar to the journal bearing elements of the "CH" bearings, with self-aligning shells, usually identical and interchangeable with the "CH" shells, and pressure lubrication. The oil is then taken from, and returned to, the pressure system created in the "CH" bearing by its oil circulator. Flange

details for equal bearing sizes are like those of the "CH" bearings.

Style "C" bearings are designated by the journal diameters.

When Style "C" bearings cannot be piped to the oiling system of an adjacent "CH" bearing, they may sometimes be equipped with a special form of oil circulator, attached to the shaft and dipping into an oil bath. Always consult us about such special designs.

Special Thrust Bearing for High Speeds

The bearing shown in Figure 20 is designed especially for high-speed, turbine-driven pumps. It embodies, in a different form, the principle of the Oil Control Ring by which oil is centrifugally expelled before it can become heated by recirculation and churning.

The thrust bearing is built into the pump housing, around one of the journal bearings, which becomes part of the thrust assembly. There are two collars, inner and outer, with the journal bearing between them. The split journal bearing serves, in effect, as a two-way base ring for the leveling plates and the thrust shoes. Enclosing each collar and its shoes is a cup-shaped, split bronze case, made in halves, with a horizontal discharge slot for oil above the working face of the collar. Surrounding each shell is an annular duct receiving oil from the discharge slot.

Oil under pressure is fed first to the journal

bearing. By grooves and drilled outlets, it issues horizontally between the shoes and meets the collars. Reaching the collar rims, it is thrown outward, as by the impeller of a centrifugal pump, through the discharge outlets above the collars, and runs outside the case down to the drain. The rate of flow is proportioned to carry off the heat of oil friction with but moderate rise in temperature. There is no definite oil level when running, since the oil, after wetting the collar, is immediately expelled; but the housing is so arranged that, when not running, oil fills the thrust cavity to the center line. This assures a supply of oil for the next start.

The seal rings confine the oil to the working spaces. Drain holes in the bottom of the cages allow sediment to escape.

All parts except the thrust collars and the oil seal rings are removable radially when the top half of the housing is lifted.

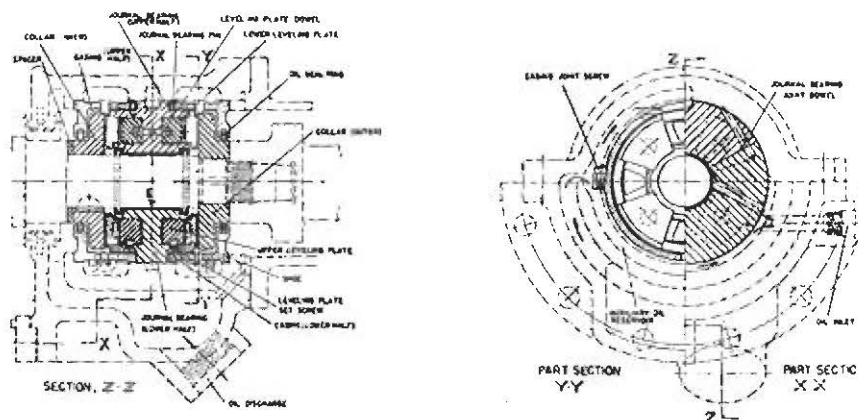

Figure 20
Special Horizontal Thrust Bearing suitable for high-speed operation.

Thrust Bearings for Vertical Shaft Pumps

Vertical pumps for which Kingsbury Thrust Bearings have been supplied include deep well pumps, condenser circulating pumps, hot well pumps, municipal water works systems, mine pumps, and dry dock unwatering pumps.

In vertical service, the Kingsbury thrust bearing is usually applied to the electric motor or steam turbine that drives the pump. Consequently we are concerned chiefly with motor or turbine thrusts, and less frequently with thrust bearings built into the pump itself.

In general, Kingsbury thrusts are used to advantage for any vertical application involving high speeds, heavy loads, or both, where utmost dependability is required.

In vertical motors the thrust bearing is usually located at the top of the shaft. In most cases they are expected to run for long periods with minimum attention: therefore the usual mounting consists of an oil pot, either separate or built-in, in which the thrust elements can run completely submerged. Heat due to oil film shear, if too much to be dispersed by air cooling, is withdrawn by circulation of water through a coil in the bath. In some applications the oil in the bath is pumped through an external cooler and returned.

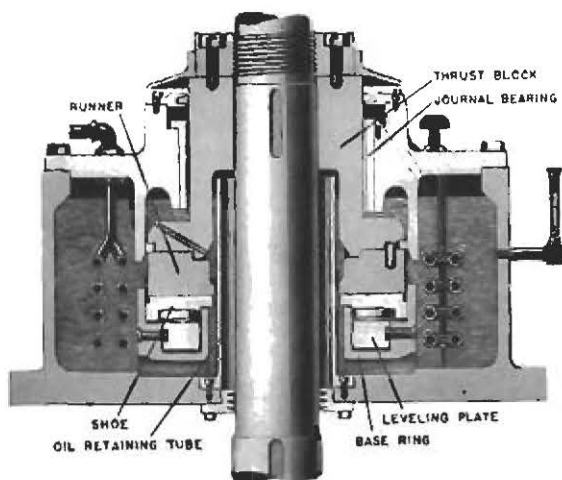

Figure 21
Assembly of thrust bearing for vertical circulating pump turbine.

Standard six-shoe bearings embody the same shoes, leveling plates and base ring as horizontal bearings, plus a vertical "runner" replacing the horizontal collar. An oil-retaining tube prevents the oil from running down the shaft. A journal bearing just above the thrust bearing can be fed with oil from the bath by using either centrifugal force or the viscosity pumping ring principle to lift the oil.

Figure 21 is typical. In this design, the hub of the thrust block constitutes the guide bearing journal. The housing cover is extended to form a space closed by a seal ring. Oil is forced up by centrifugal action into that space, then through a groove in the guide bearing, and it overflows from the top back into the oil bath. Thus oil is retained for the next start.

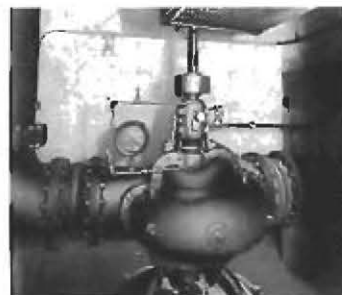

Figure 22

These photographs show a motor and pump in the Victoria Station of the Central Power & Light Co., Victoria, Texas. A Kingsbury Thrust Bearing is located in the base of the motor and carries the thrust of the rotating element.

The thrust elements are usually Style KV (six shoes) or LV (three shoes); see Figures 23 and 24. The base rings have raised rims, which retain the shoes in radial position. This is usually more convenient for the designer than to employ other means to hold the elements in place.

Oil rising through the thrust elements is expelled centrifugally between the runner and the shoes and it is cooled by contact with the coil.

The usual short guide bearing shown in Figure 21 is ample for the nominal radial loads usually involved. If, however, a heavy radial load is anticipated, as sometimes with a belt or gear drive, the guide bearing can be lengthened as needed.

When the work required of a guide bearing is light the runner or thrust block rim may be polished and act also as a journal.

Figure 25 shows a bearing with a spherical runner. A runner of this shape requires no guide bearing for the radial loads usually encountered; and, unlike the conventional journal bearing, it runs with zero radial play. This feature is

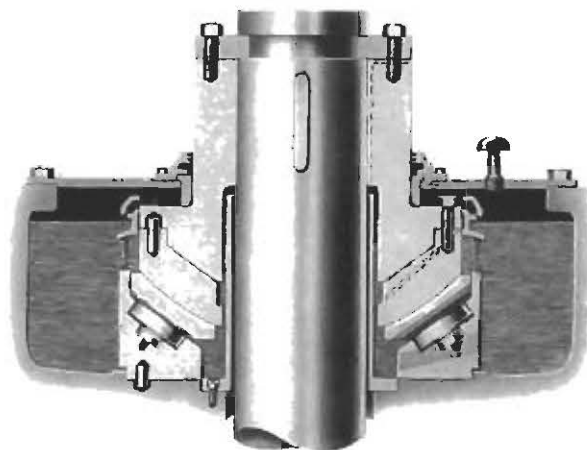

Figure 25
Typical Spherical Bearing.

sometimes valuable in electrical machines, especially in the larger sizes and higher speeds. Information on spherical bearings will be given on request.

If the speed is moderate, a vertical bearing may be designed to run air-cooled by making the housing with fins for better heat dispersal. In that case, the oil is of higher viscosity than would otherwise be chosen, to permit running at higher temperature. We should be consulted regarding all such cases.

In vertical steam turbines driving pumps, the usual high speed makes it impracticable to use a water cooling coil in an oil reservoir. Instead, an external lubricating and cooling system is used, common to all the bearings of the pumping unit, like the arrangement regularly used in horizontal turbine machinery. It is highly important to have oil flowing, or at least present in the bearing, before the shaft starts to turn.

At high speeds, power loss in vertical pump thrusts may be minimized by using the Oil Control principle in the arrangement shown in Figure 26, page 18. In this design, oil under pressure enters the radial bearing first, and runs down to the thrust cavity. The runner is shaped with a flange at its lower face, by which the oil is thrown off, after wetting the face and shoes, into a surrounding groove in the housing. A tangential outlet leads to a discharge passage, which is carried high enough to ensure retaining some oil on stopping, to wet the runner face for the next start.



Figure 23
6-shoe thrust bearing for vertical shaft. Runner is shown in phantom.



Figure 24
3-shoe thrust bearing for vertical shaft. Runner is shown in phantom.

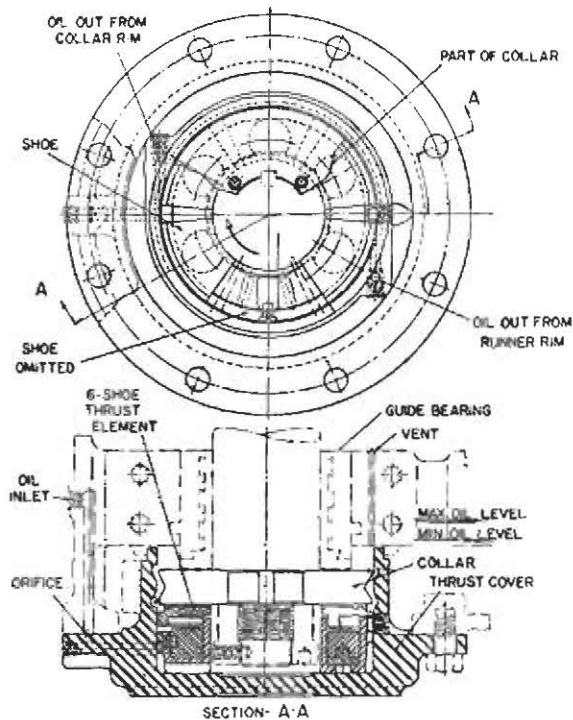

Figure 26

Arrangement of a vertical step-bearing for high speed with oil control feature in discharge from collar rim.

Vertical Mounting Arrangements

In addition to the bearings described and illustrated on the preceding two pages, various vertical thrust bearing arrangements are illustrated in figures 27, 28, and 29.

Figure 27 shows a simple form of thrust bearing for a suspended shaft. The housing is integral with the machine frame and provision is made for a radial bearing just below.

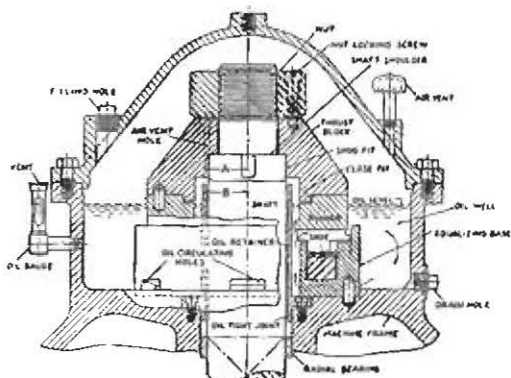

Figure 27

Typical application of thrust bearing at top of motor shaft.

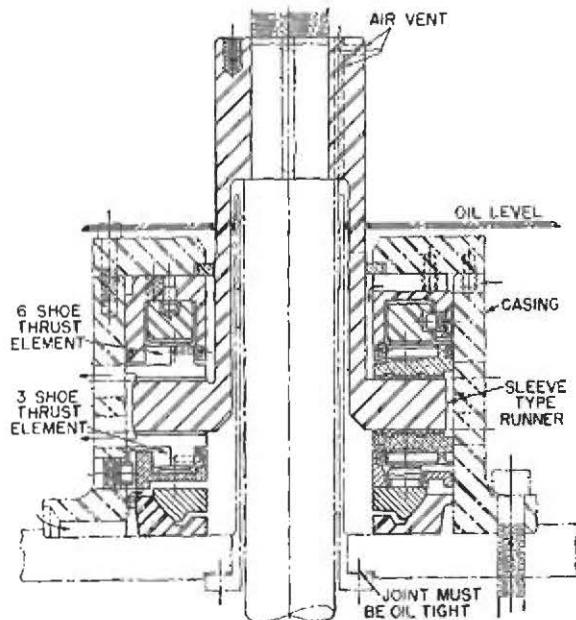

Figure 28

6-shoe and 3-shoe combination for vertical unit where major thrust is in upward direction.

Figure 28 shows an arrangement suitable for a vertical pump drive in which the major thrust is upward. The six-shoe equalizing type thrust element acts on the upper surface of the combined thrust block and runner, while a three-shoe element acts on the under face to absorb reverse thrust, when it occurs.

A step bearing for the bottom of a shaft is shown in figure 29. A six-shoe bearing takes the principal (downward) load and a three-shoe element provides for reversal of thrust.

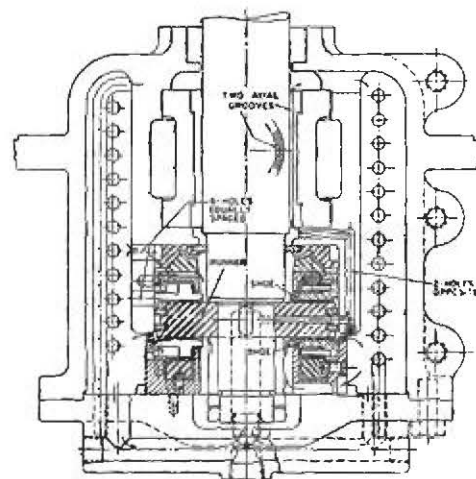

Figure 29

6-shoe and 3-shoe step-bearing for vertical unit where principal thrust is in downward direction.

Separate Vertical Guide Bearing

For long vertical shafts, one or more separate guide bearings are essential. Since these are likely to be inconvenient to reach, automatic oiling is very desirable. This should include an ample oil reservoir (air cooled if possible), protection from dirt, and automatic circulation of the oil in the bearing. All these requirements are covered in the bearings shown in Figures 30 and 31.

Oil is circulated by centrifugal action at ordinary speeds; by viscosity pumping at low speeds.

For detailed recommendations consult us, giving full particulars of service intended.

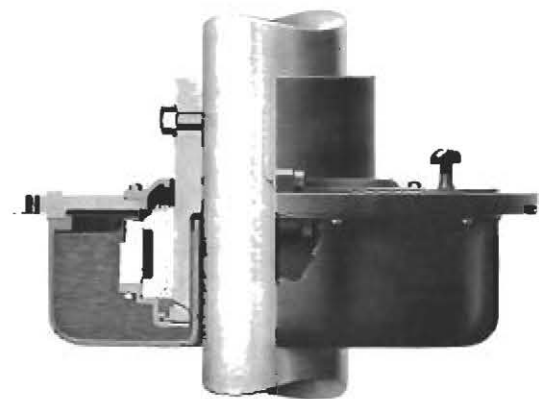

Figure 30

Independent guide bearing, submerged type, with fixed shell guide and one-piece oil well.

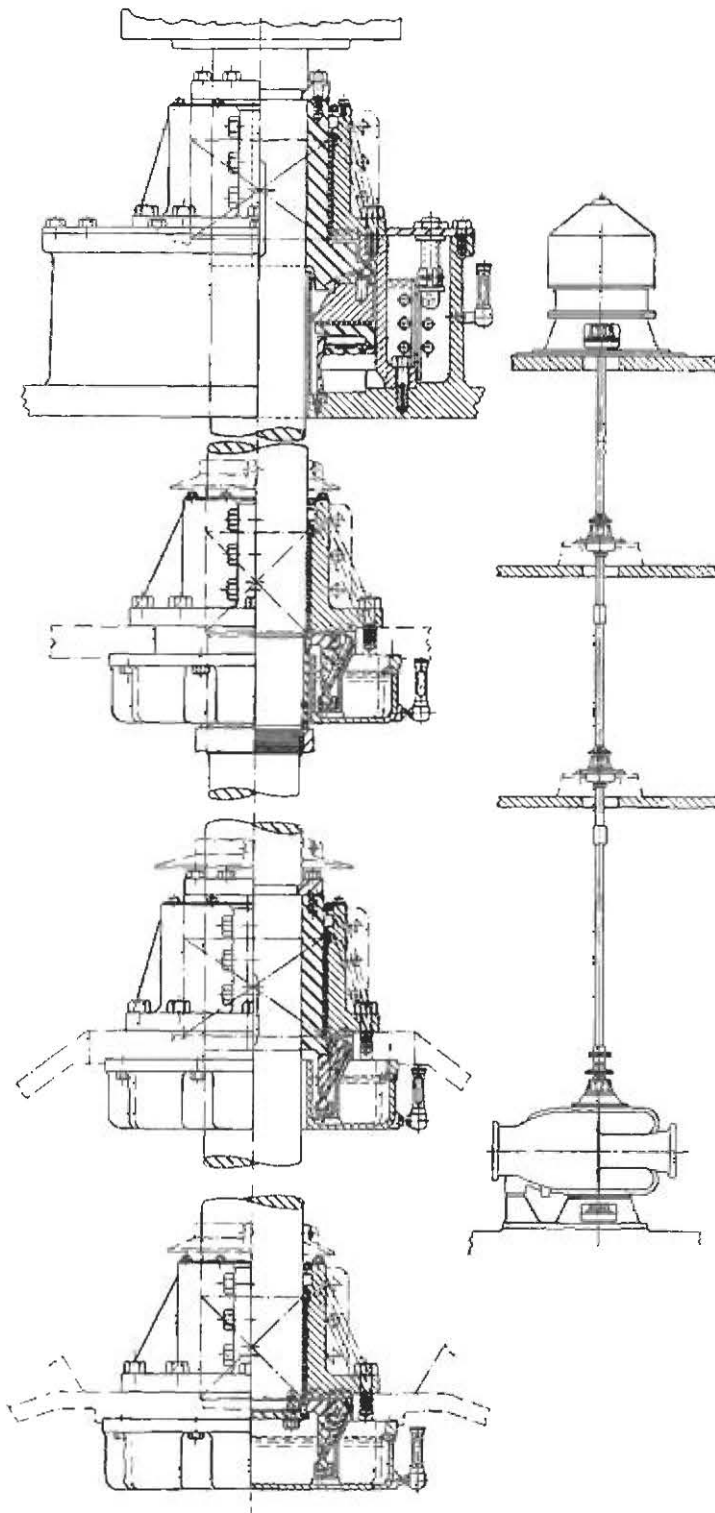

Figure 31

Combined thrust and guide bearing and three independent guide bearings, for condenser circulating pump. Oil circulates to each of the guide bearings by centrifugal pumping action.

Data Needed With Inquiries

To make specific recommendations, we should have the fullest possible information on the conditions to be met, as follows:

Is shaft vertical or horizontal?

Thrust load, in each direction.

Journal bearing load (if unusually heavy).

Direction of journal bearing load (if not obvious).

Shaft speed.

Shaft diameters in way of bearing.

Is cooling water available?

Is external lubricating and cooling system available?

Sketches showing shaft construction, mounting conditions, and space limitations.

Standard Guarantee

Any bearing or part furnished by us, which shall prove defective in design, material or workmanship, within one year after installation and test, will be replaced without charge f.o.b. Philadelphia, if returned to our factory. This period is, however, limited to a maximum of two years from date of shipment from the fac-

tory. No allowance will be made for labor or other expense in connection therewith unless authorized in writing by an officer of the Company.

For oil coolers and cooling coils, in accordance with usual trade practice, there is no specific guarantee period.

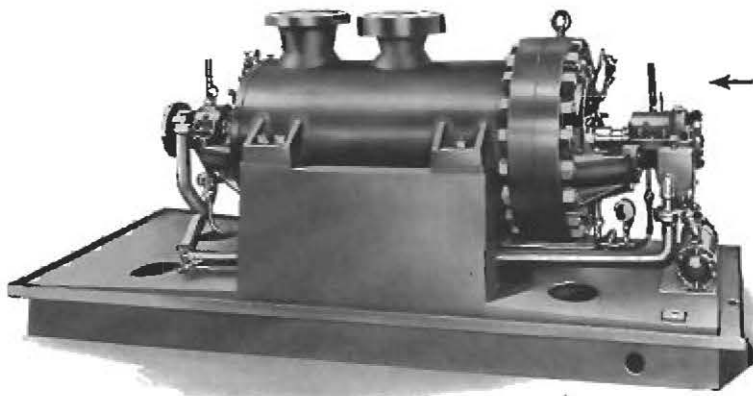

Photo Courtesy Byron Jackson Co.

← Byron Jackson Seven Stage High Pressure Boiler Feed Pump equipped with Kingsbury Style "CH" Thrust and Style "C" Journal Bearings.

Le Courtenay 6" Four Stage Centrifugal Pump fitted with Kingsbury Style "CH" Thrust Bearing. →

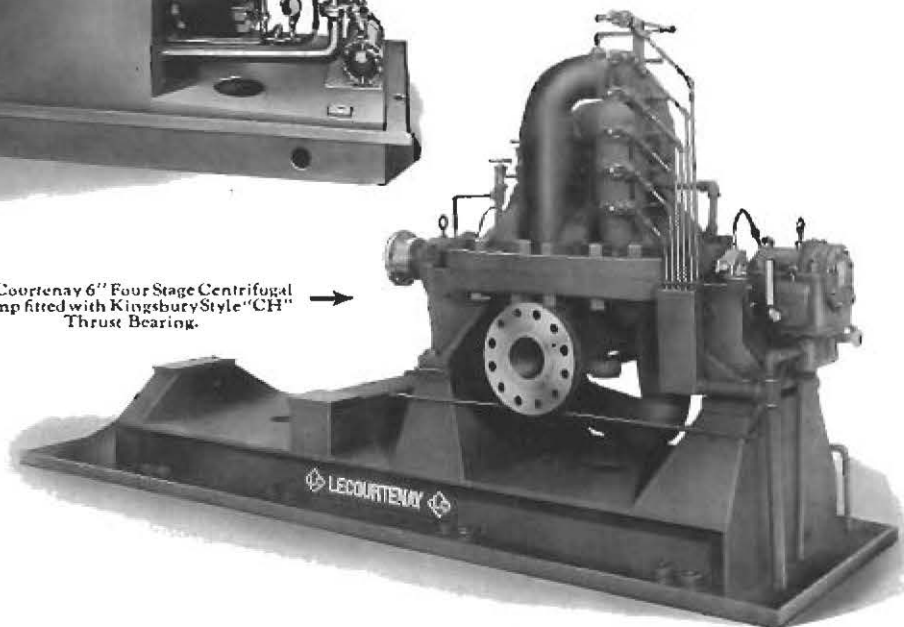

Photo Courtesy Wilson-Snyder Div., Oil Well Supply Co.

