KINGSBURY BEARINGS

**for
Dredge Pumps
and
Dredge Propulsion**

Bulletin D





Dredge "Hydro-Quebec" at work on the Beauharnois Canal.

Photo Courtesy: The Ellicott Machine Corporation and the Commissioners of the Beauharnois Light, Heat and Power Company

KINGSBURY

Thrust and Journal

BEARINGS

for

DREDGE PUMPS

and

DREDGE PROPULSION

BULLETIN D



KINGSBURY MACHINE WORKS, INC.

Main Office and Works

FRANKFORD, PHILADELPHIA 24, PA.

CONTENTS

Foreword	5
The Kingsbury Principle	6
Requirements for Dredge Pump Bearings	7
Six-Shoe and Two-Shoe Thrust Arrangements "Equalizing" and "Adjustable"	7
Six-Shoe Thrusts for Higher Powers	9
Two-Shoe Thrusts for Lower Powers	10
Axial Adjustment	11
Load Ratings—What They Mean	12
Thrust Capacity and Speed	13
Journal Bearings.	14
Lubrication and Cooling	15
End Closures	15
Foundation Construction	16
Notes on Installation	17
Cutter-Shaft Applications	19
Self-propelled Dredge Propeller Thrusts	19
Spare Parts	20
Data Needed for Bearing Selection	20
Standard Guarantee.	20

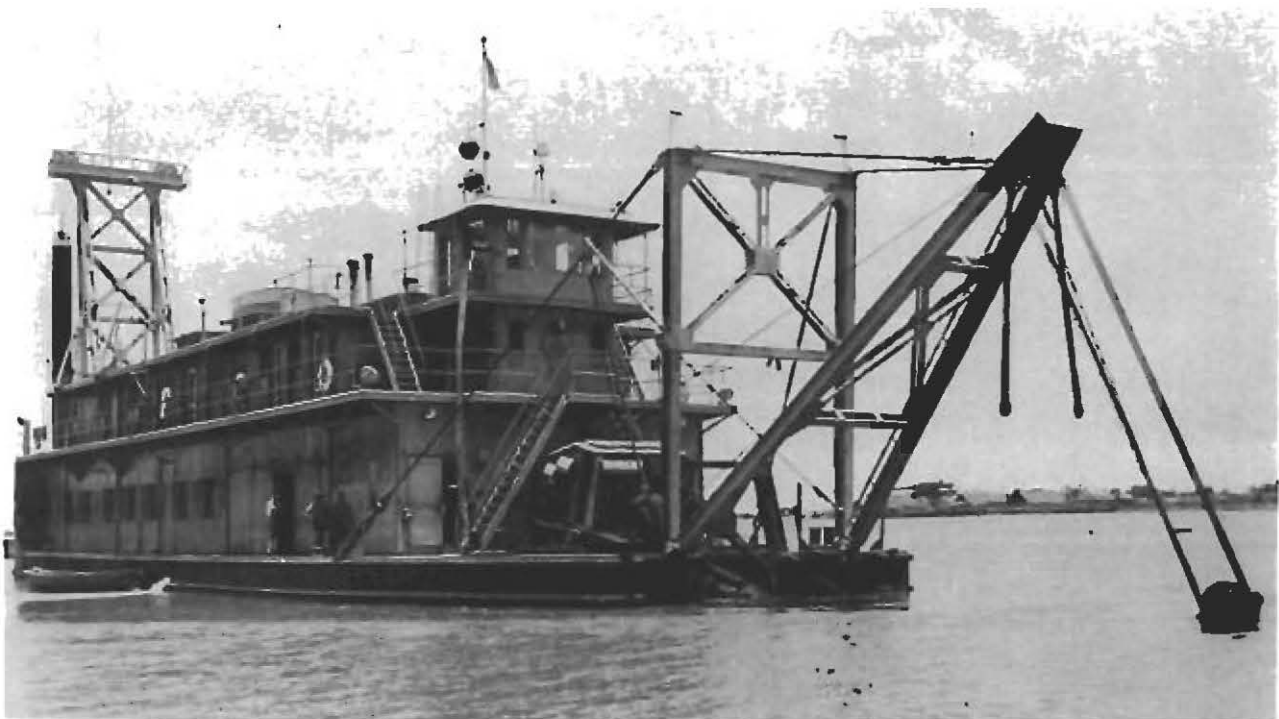

Dredge "Musi" designed and built by Ellicott Machine Corp. for Indonesian Government.

Photo Courtesy Ellicott Machine Corporation

FOREWORD

This Bulletin covers mainly the application of Kingsbury Thrust and Journal Bearings to centrifugal dredge pumps, especially in the heavy-duty category. It describes the types of bearings chiefly used; their arrangement, lubrication and cooling, and installation.

The basic elements of Kingsbury Bearings are described more fully in the Kingsbury Guide Book, which also includes discussion of the various fields of application of these bearings. It should be read as a general introduction to the specific uses covered in this and other Bulletins.

Separate booklets, furnished on request, contain full data on dimensions, load capacities and weights of the various types of standard bearings commonly installed on dredges.



Dredge "Franciscan," a West Coast giant with 8000 pump h.p.

Photo Courtesy Yuba Manufacturing Co.

The Kingsbury Principle

Kingsbury bearings make full use of the natural adhesion of oil to the rotating thrust collar, which draws the oil in between the working surfaces in a positive and powerful manner. This is possible only because the stationary surface of the bearing is composed of a number of pivoted segments that tilt slightly, permitting entry of oil, and formation of wedge-shaped oil films.

The segments, called *shoes*, and the collar faces are flooded with oil, under only nominal pressure. However, rotation of the collar builds up tremendous pressures in the oil films, as required to carry heavy thrust loads.

Oil enters the film at the leading edge, where the opening is widest, due to the pivoted mounting of the shoes. Urged along by the remarkable property of adhesion, the oil flows under steadily increasing pressure toward the center of the shoe, thence toward the trailing edge, and the inner and outer edges, under diminishing pressure. The result of this action is the formation of a self-renewing wedge-shaped oil film that positively separates the bearing surfaces and prevents wear.*

*References to technical literature discussing oil film behavior, and the relationship between load, speed, viscosity, film thickness and resultant friction, will be supplied upon request.



View of the Engine Room of the dredge "Hydro-Quebec" showing the machinery of one of the world's largest Pipe Line Dredges, an important production unit in the dredging of the Beauharnois Canal, part of the St. Lawrence Waterway System.

Photo Courtesy Elliott Machine Corporation, builders of the dredging equipment, and the Commissioners of the Beauharnois Light, Heat and Power Company

Requirements for Dredge Pump Bearings

In a dredge pump, the elements which unavoidably wear and must be replaced are the impeller, the shaft gland, and the casing, the side head liners and the suction throat liner. Those are the elements exposed to abrasion by the mud or sand, stones—even rocks—which pass through the pump.

The ideal of dredge pump engineering is to confine the wear to those parts, since their replacement can be timed according to the working schedule and the nature of the material handled. On that basis the pumping unit can be planned for maximum performance and an absolute minimum of unscheduled shut-downs.

Admittedly this describes an ideal goal. However, one definite step in that direction can be taken with what are—next to the pump itself—the most important “wearing parts” of the pump assembly: namely, the pump bearing and the thrust bearing. Regarding these, the designer is free to choose either bearings which inevitably wear out (even if slowly) or bearings which, from their inherent nature, do not normally wear out at all. Stated otherwise, he may choose either bearings which operate by rolling metallic contact, or bearings whose working surfaces are constantly separated by films of oil, so that, with clean oil supplied, they never touch and never wear. With the latter choice—Kingsbury Bearings—these “wearing” parts become *non-wearing* parts.

Kingsbury Thrust Bearings came into general use back in 1912, when the first large commercial bearing of that design was applied by Albert Kingsbury to a hydroelectric generator

at Holtwood, Pennsylvania. That bearing, sensational for its day, carried a 400,000-lb. vertical load; it has never worn out or needed repairs. Later bearings, built on the same principle, are today carrying loads of 3,000,000 lbs. and over, with similar freedom from wear and breakdown. First applied to dredge pumps in 1922, Kingsbury Thrust Bearings in suitably modified designs are helping some of the world's most powerful dredges to roll up consistently high records of performance.

Kingsbury Journal Bearings, correspondingly engineered for service next to the pump, likewise have the working surfaces continuously separated by films of oil. Like the thrust bearings, they are built to last indefinitely when protected from grit and supplied with clean oil of proper viscosity.

The lubrication requirements of a Kingsbury Bearing are not essentially different from those of an engine or turbine. They have been satisfied in these bearings by the use of carefully planned, self-contained systems, in which the oil is automatically circulated and cooled without requiring external auxiliaries.

The power loss in Kingsbury Bearings is only that due to oil shear. The coefficient of friction may be from .001 to .005, depending on operating conditions. Due to their design (explained on page 6 under “The Kingsbury Principle”), both thrust and journal bearings run with thicker-than-usual oil films.

Those film cushions give a very high factor of safety under shock loads—an especially desirable feature in dredge pump operation.

Six-Shoe and Two-Shoe Arrangements

“Equalizing” and “Adjustable”

In dredge pump bearings there are either six or two shoes—six for higher power, two for lower. Two shoes are frequently used also on the unloaded side of the collar in six-shoe bearings, to limit the end play and take any momentary back thrust.

In six-shoe bearings the load is divided equally among the shoes by means of a series of interlocking levers, called *leveling plates*, which are held in a *base ring* as shown diagrammatically in Figure 1. The “upper” leveling plates support the shoes, and are backed in turn by the “lower”

leveling plates. Both upper and lower leveling plates are free to rock slightly till all the shoes bear equal loads. The shoes also are free to tilt, thereby giving the oil films the exact form and taper to suit the load, speed and oil viscosity.

The same combination of rocking and tilting makes the bearing self-aligning, to allow for slight misalignment or deflection of the thrust shaft.

The backs of the shoes have hardened inserts, with rounded pivots bearing against hardened contact surfaces of the upper leveling plates. The shoes are cast steel, faced with hard babbitt, machined and scraped to a surface plate. The radial edges are slightly rounded. The collar is forged integrally with the shaft; its faces are machined square with the shaft axis and are lapped dead smooth. To permit radial assembling, the base rings are split.

The two-shoe elements used opposite the six-shoe heavy-duty elements are usually of the "adjustable" type. The two shoes are supported on jack screws, which may be adjusted manually to equalize the loading. The shoes, located left and right of the shaft axis, have the usual hardened, pivoted inserts.

Two-shoe adjustable type bearings are used for both directions of thrust in lower powered applications where the maximum thrust load is moderate. The basic design is illustrated in Figure 2, showing the shoes and adjusting screws only.

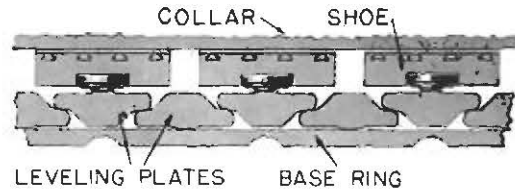

Figure 1
Developed diagram showing principle of equalized support of shoes by use of leveling plates.

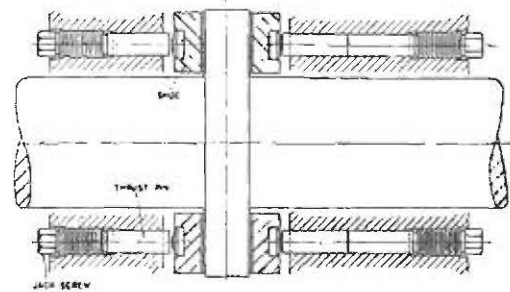

Figure 2
Horizontal section of two-shoe bearing showing arrangement of spacing pins and adjusting screws.

The shoes are located a little below the shaft center, in the housing base. Each shoe is backed by a massive jack screw, and equal division of the load between them is obtained by careful adjustment of the screws. Self-alignment is therefore assured in a vertical plane.

The end play is set by adjusting the jack screws on the unloaded side.

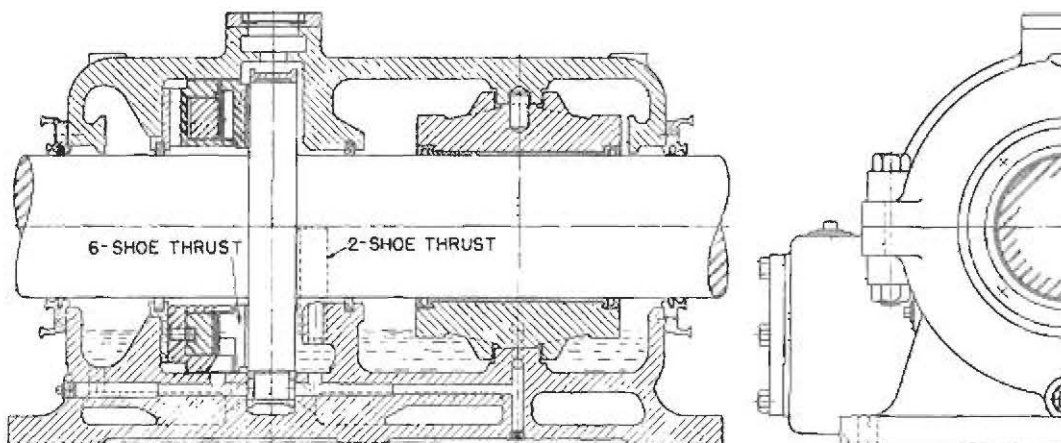

Figure 3
Section through six-shoe and two-shoe Thrust Bearing with self-aligning Journal Bearing.

Six-Shoe Thrusts for Higher Powers

The typical thrust bearing assemblies for heavy-duty dredge pumps are those illustrated in Figures 3 and 4. The pump-end journal bearing is placed as close to the overhung impeller as necessary clearances for packing glands will permit, as indicated in Figures 15 and 16, page 17, and Figures 17 and 18 on page 18. The thrust bearing is at the other end of the shaft, with its built-in journal bearing next to the drive coupling. The pump-end journal bearing is made self-aligning, partly to correct any slight errors in the assembly, partly to accommodate the shaft flexure which is bound to occur with an unbalanced weight in the impeller. The load-carrying thrust bearing elements are of the six-shoe equalizing type, which is inherently self-aligning. The thrust-end journal bearing may be either of the fixed, or of the self-aligning type.

For those cases in which space is at a premium, the axial length of the pump unit can be reduced by the use of a bearing assembly having two self-aligning journal bearings with the thrust bearing between them, in a single housing.

The system whereby oil is circulated applies in another way the principle of oil adhesion. No moving parts are added. Surrounding the collar rim is a stationary bronze ring, called the "circulator," having a wide shallow groove in its bore. The circulator is a free fit on the collar, and is as wide as the rim. Both collar and circu-

lator dip into the oil bath in the housing base. At the top and bottom, the circulator is held by recessed lugs in the cap and base. The lugs, and the circulator itself, are drilled to permit entry and escape of oil, to and from the groove in the bore, as required for circulation.

Oil entering the circulator groove at the bottom meets the moving collar rim, and is drawn around inside the circulator by adhesion to the collar. Either at the top, or approaching the bottom on the farther side, it meets a dam across the groove. Pushed by the oil behind it, it issues under pressure—several pounds per square inch—and flows through passages which lead it, partly to the thrust bearing shoes, partly to the built-in journal bearing, partly to the pump-end bearing, and partly to the oil cooler attached to the side of the housing. At any operating speed the flow provides ample lubrication.

The obvious advantage of this method of circulating the oil is that it involves no valves, no moving parts (except the collar itself) and nothing to wear out. Circulation starts when the pump starts: oil held by capillary attraction between the bearing surfaces is ample for the first few turns; and all bearings are assured of the fresh flow by the time the load comes on. Experience with hundreds of pumps has proved the complete dependability of this simple method of circulating the oil.

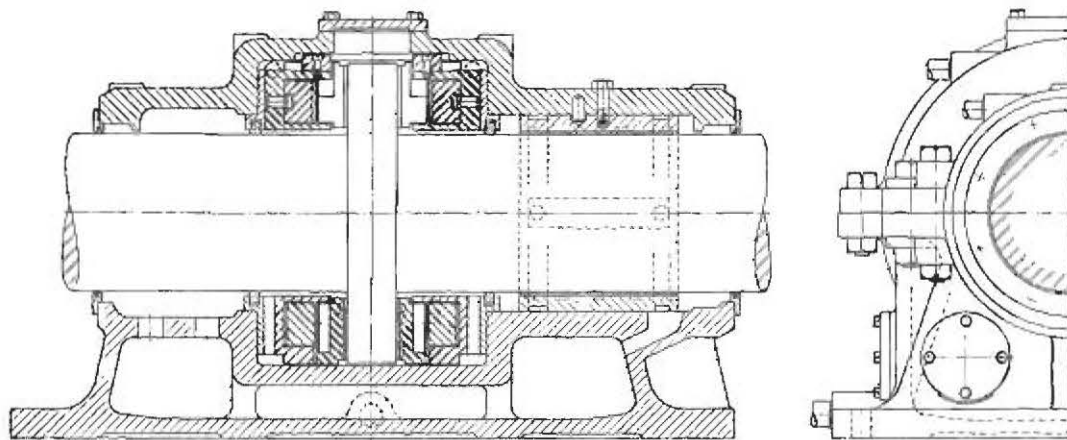

Figure 4
Section through double six-shoe heavy duty Thrust Bearing with fixed-axis Journal Bearing.

Two-Shoe Thrusts for Lower Powers

For lighter duty, not requiring a six-shoe bearing, the two-shoe type, shown in principle in the phantom view Figure 5 and in section in Figure 6, is a logical choice. For equal collar diameter its capacity is about 40 percent of the six-shoe capacity; but it is likely to be used with a somewhat larger shaft and collar.

The collar dips into a bath of oil in the housing base; and oil carried around by adhesion to the rim is taken off at the top by a bronze scraper riding on the rim, and distributed to both faces of the collar and also to the built-in journal bearing. That bearing is not self-aligning in standard models. The thrust element is self-aligning only in the vertical direction.

A water cooling coil, in the base or attached to the side of the housing, supplements air cool-

ing by disposing of the heat due to oil friction at pumping speeds.

Usually the pump-end journal bearing is supplied with oil circulated from and back to the thrust bearing. When the latter is of two-shoe type, the pressure and volume of flow needed for this purpose are generated by using an "oil pressure scraper," shown in Figures 6 and 7 (page 11). Its principle is similar to that of the ring type of oil circulator, but it operates only on a small arc of the collar rim. A wide shallow groove in its underside ends in a dam at the farther end, and the oil meeting the dam is pushed out under moderate pressure. Part goes to the built-in journal bearing, part to the pump-end bearing, and part to the cooler if that is outside the housing. Surplus oil reaching the scraper runs down and floods the collar faces.

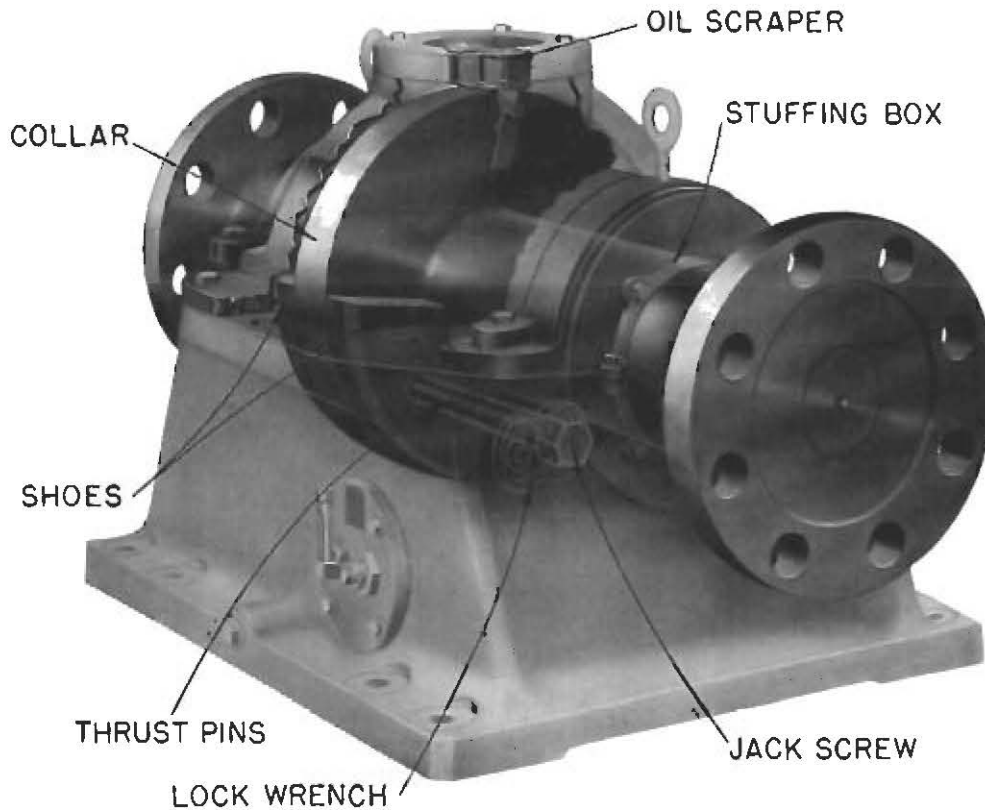

Figure 5
Medium-size two-shoe adjustable Thrust Bearing. Part of housing is broken away; part is in phantom, to show internal parts.

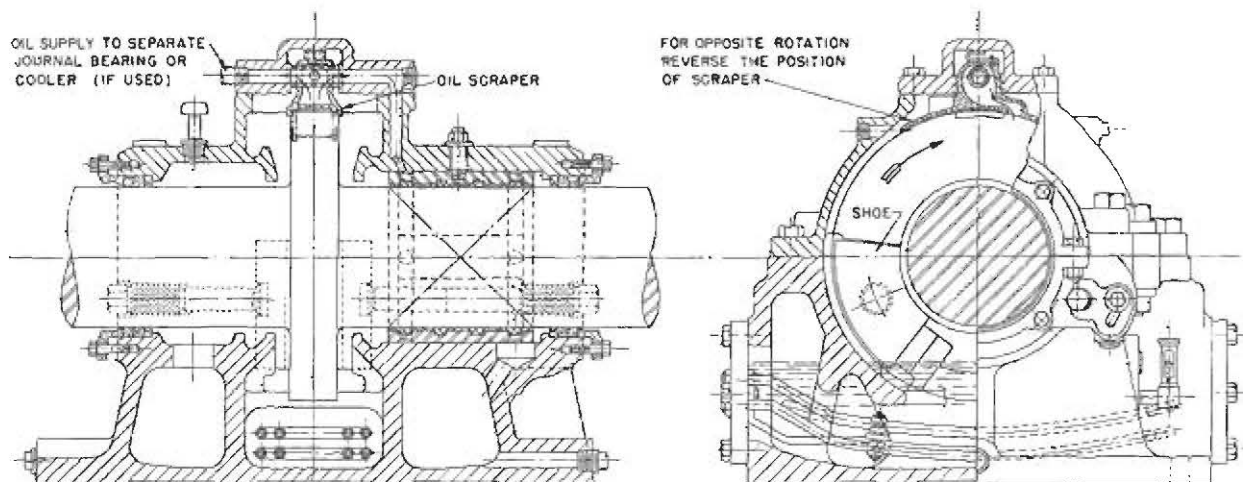

Figure 6
Two-shoe Bearing with Pressure Scraper.

Axial Adjustment

In thrust bearings having six-shoe equalizing elements for both directions of thrust, the internal end play and the axial position of the shaft are both determined by the thickness of machined filler plates placed behind each base ring. Obviously, any adjustment of end play and/or axial position is accomplished by grinding one filler plate and shimming the other, or replacing it with a thicker one.

In six-shoe bearings having a two-shoe adjustable element on the lightly loaded side, the housing is carefully located axially with the thrust collar bearing against the six shoes so that the pump impeller will be in the desired endwise position, and then secured to the bed plate. Then the two shoes are adjusted by means of their jack screws to give the desired total end play, which should be checked by jacking the shaft back and forth from one limit to the other.

There are numerous ways in which the bearing housings can be secured to the bed plate in order to simplify the axial location and at the same time fasten the parts together with the necessary rigidity to withstand the shocks incident to dredging operation.

One arrangement, illustrated in Figure 15 in which a cast bed plate is used, consists of providing cast transverse sills on the bed plate, far enough apart so that adjusting wedge keys can be inserted between the sills and the ends of the bearing housing. The keys determine the axial



Figure 7
Pressure Scraper used with
two-shoe Thrust Bearings.

location, and therefore clearance bolts are adequate to secure the housing to the bed plate.

A similar arrangement on a fabricated bed plate may be seen in Figure 16 in which heavy transverse angles are welded to the bed plate and keys are used to locate and adjust the bearing housing axially while bolted guides restrain it against transverse movement. Here, again, the holding-down bolts are relieved of shear stresses.

A third scheme involves the provision of a plate between the housings and the bed plate, the holding down bolt holes in this plate being slotted and a stop with jack screws being provided to hold the plate in the desired axial location. In this arrangement fitted bolts hold the bearing housing to the plate.

Any one of these devices will prove satisfactory if the scantlings of the plates, bars and bolts are made large enough safely to withstand the maximum loads.

The end play should be approximately one thousandth of an inch per inch of thrust bearing diameter, plus .005, but the designed value and the allowable tolerances are shown on the assembly drawing for each application.

Load Ratings: What They Mean

We have found no definite speed limits for Kingsbury thrust bearings. Because the shoes are free to tilt, increasing speeds tend to draw more oil between shoes and collar, thereby adding to the load capacity; and this fact is taken into account in the rating tables.

Stated accurately, the load capacity cannot be expressed in "pounds per square inch"; it depends on the thickness of the films of oil. And the film thickness depends not only on load and speed, but on the size and proportions of the shoes and on the operating viscosity. Viscosity, in turn, depends on grade of oil and temperature. The general design and bearing size must be

chosen to suit the load, speed and grade of oil. In all cases, provision must be made for removing the heat of oil friction. These facts explain why we should have full particulars regarding intended use.

Our rating tables specify load capacity for given size and number of shoes, of given bores to suit shaft diameter, at given speeds, with oil of "standard" viscosity. Other things being equal, the load capacity is roughly proportional to the viscosity at bath temperature; but this is limited by the unsuitability of heavy oil for high speeds. The following examples are taken from the standard rating tables:

Table I

Typical Ratings, Two-Shoe Adjustable Bearings

Loads in Pounds

Bearing Size	Bearing Area Sq. In.	100 r.p.m.	200 r.p.m.	400 r.p.m.	800 r.p.m.
12	27	5,100	5,700	6,500	7,200
15	43	9,500	10,700	12,000	13,500
19	72	18,800	21,200	24,000	
23	105	30,000	33,000	38,000	
27	141	41,000	46,000	52,000	
33	211	65,000	73,000		

Table II

Typical Ratings, Six-Shoe Equalizing Bearings

Loads in Pounds

Bearing Size	Bearing Area Sq. In.	100 r.p.m.	200 r.p.m.	400 r.p.m.	800 r.p.m.
12	72	17,500	19,500	22,000	24,700
15	112.5	30,500	34,000	38,500	43,000
19	180	54,000	61,000	68,000	77,000
23	264	86,500	97,000	109,000	
27	364	128,000	143,000	161,000	
33	544	209,000	234,000	264,000	

In these tables, "bearing size" is the outside diameter of the bearing surface of the shoes; the collar is a little larger. Numerous other sizes are omitted. For two-shoe bearings, the ratings given are averaged between those for the smallest and largest shoe bores to accommodate various shaft diameters.

The ratings assume that the cooling system

(air, water, or oil circulation) and the choice of oil will result in a bath viscosity of 150 to 200 Saybolt, at the actual operating temperature.

In service afloat, loadings should be more conservative, and oils somewhat heavier, than for land work. We should always be consulted regarding the final choice of bearing size and design for a new application.

Thrust Capacity and Speed

Approximate Thrust Loads for Dredge Pumps

Table III

The safe unit pressure for a Kingsbury Bearing depends chiefly upon three factors: bearing size, shaft speed and oil viscosity. An increase in any of these factors permits an increase in the unit pressure without changing the operating thickness of the oil film.

For specified diameters of thrust collar and shaft, the load capacity is approximately proportional to the area of the bearing shoes. The capacity per square inch of loaded area is, however, greater for large bearings than for small ones.

The larger shaft sizes, in a given thrust bearing mounting, reduce somewhat the available thrust bearing capacity.

Consult us freely about all unusual conditions, such as loads, unit pressures, and speeds outside the range given.

Impeller Diameter (Inches)	R.P.M.	Approximate Thrust Load (Pounds)
50	600	18,000 - 30,000
	400	8,000 - 13,500
	250	3,000 - 5,200
60	500	28,500 - 47,000
	350	14,000 - 23,000
	200	4,500 - 7,500
70	450	45,000 - 77,000
	300	21,000 - 34,000
	175	7,000 - 11,500
80	400	67,000 - 110,000
	275	32,000 - 52,000
	160	10,500 - 17,500
90	350	85,000 - 140,000
	250	44,000 - 72,000
	150	16,000 - 26,000
100	325	110,000 - 200,000
	225	58,000 - 97,000
	135	22,000 - 34,000
110	300	157,000 - 250,000
	200	70,000 - 127,000
	125	27,000 - 44,000

Note: Diameter of suction opening assumed to be from 35 to 45% of impeller diameter. Impeller assumed to have no pressure balancing holes.

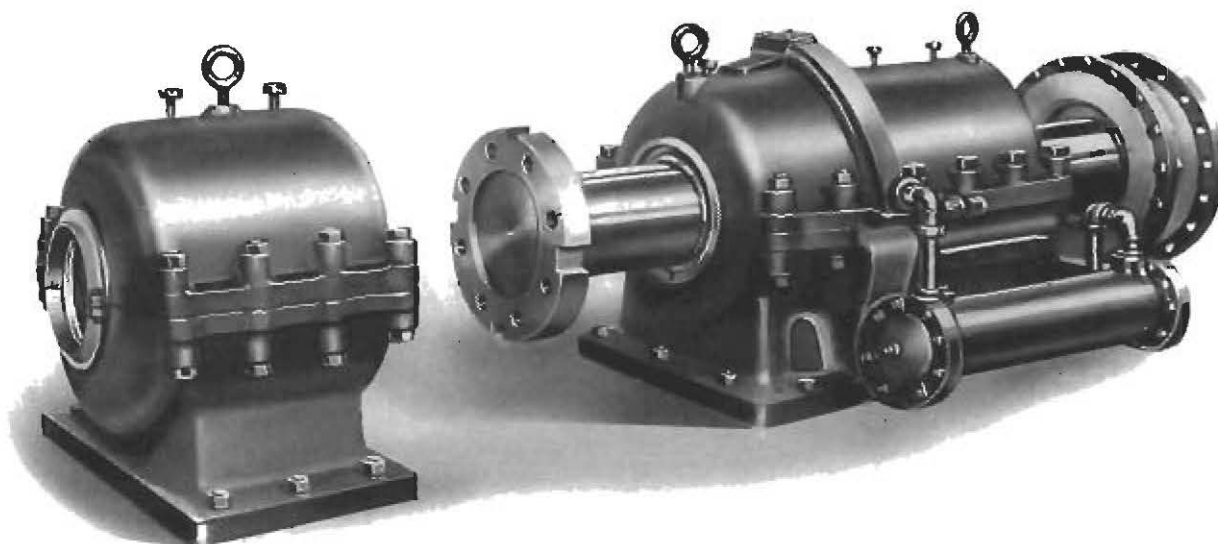

Figure 8

View of six-shoe Thrust Bearing and self-aligning Journal Bearing placed in approximately relative positions.

Journal Bearings

The Kingsbury Journal Bearing is essentially a simple, sturdily built split-shell bearing consisting of a cast steel shell lined with tin-base babbitt. Since the bore of the bearing is slightly greater than the diameter of the journal, there is room for the formation of a wedge-shaped film of oil between the bearing and journal surfaces so that as long as a sufficient quantity of lubricant is admitted to the downward-moving side of the journal there will always be a film of oil to separate the moving from the stationary parts and no metallic contact takes place.



Figure 9
Special self-aligning separate Journal Bearing with end closures.
Built for dredge pump service.

Journal Bearing Grooving

Because the journal bearings are self-aligning, they are assured of substantially uniform film thickness throughout their length. In addition, they are grooved to assure both freedom from foaming, which might reduce their load-bearing capacity, and a volume of flow through the bearing sufficient to absorb and carry off the heat due to oil shear. Oil under pressure enters a wide groove at one side of the bearing. Part of it is carried around by the shaft to an

The bearing shell is supported in the housing on a rib whose axial length is small in proportion to that of the bearing shell and consequently the bearing is substantially self-aligning. This type of support is indicated in the illustration, Figure 3, in which the journal bearing is of the self-aligning type.

An important factor in the design of a journal bearing for maximum efficiency is provision for proper oil flow to the journal surface.

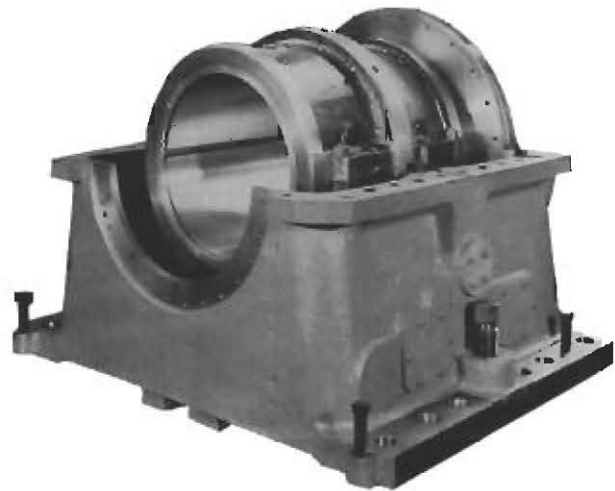

Figure 10
Large self-aligning Line-shaft Bearing with oil circulator for
lubrication (housing cover removed).

outlet groove on the other side: part reaches the outlet groove via circular grooves connecting the side grooves, close to the ends of the bearing shell. Thus the journal is both lubricated and cooled by the oil flow.

Because of the uniform distribution of load due to self-alignment, and the absence of foaming, these journal bearings carry exceptionally heavy loads. It is usually unnecessary to make the effective length of the shell (between the end grooves above mentioned) greater than the bore; and that proportion is standard.

Lubrication and Cooling

The basic principles of Kingsbury lubrication are: (1) to flood the bearing surfaces with oil, thus giving full opportunity for the oil films to assume the wedge form; (2) to circulate the oil rapidly enough to remove the heat due to shearing of the films; (3) to suit the viscosity to the load and speed. The methods of doing these things depend on conditions.

In dredges it is usually preferable or necessary that the thrust bearing shall be completely self-contained, with its own devices for circulating and cooling the oil. Most two-shoe horizontal adjustable bearings, Figures 5 and 6, are in this class. The oil is circulated by the thrust collar, dipping into the bath of oil. When the speed is high enough to require water-cooling, a copper coil is installed in the oil bath, or an oil cooler is mounted alongside the housing.

On an enlarged scale a similar lubricating and cooling arrangement is used for

dredge pump thrusts, with oil similarly piped to, and returned from, the journal bearing next to the impeller. An oil cup is often fitted to supply oil for starting after a long shut-down.

Using an extension of the same principle, isolated journal bearings anywhere can be lubricated by attaching a "pumping disc" to the shaft to circulate the oil.

The power loss due to oil shear under given running conditions can be calculated definitely. When using an external oil circulating and cooling system, the rate of oil flow can be stated for any desired temperature rise, usually from 10° F. to 25° F. When using an internal water cooling coil, or an attached oil cooler, the required rate of water supply can likewise be figured. For any new set of conditions, we should always be consulted regarding oil or water rates, and also regarding viscosity.

End Closures

End closures are of different types, according to whether their function is to retain oil, or to exclude water, or dirt. The simplest and most usual seal consists of a felt ring held in a bronze packing retainer secured to the end of the housing. Other seals and oil and water throwers, used singly or in combination, are illustrated in Figure 11.

Next to the simple felt ring a combination of the felt with a "comb" is most frequently used, while for severe conditions a stuffing box is usually employed.

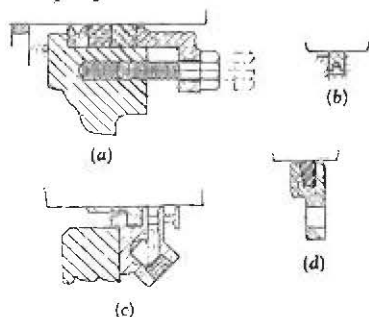

Figure 11

End closures commonly used. (a) Stuffing box. (b) Simple oil seal ring. (c) Crown Ring all-metal closure. (d) Felt ring compressed into bronze ring.

Figure 12 illustrates the "crown ring" type of closure which is especially effective in preventing leakage of oil from the housing without requiring actual contact with the shaft. The crown ring is made of bronze and floats on the shaft with slight radial freedom. It is retained axially by a bronze ring in which it is loosely held. Oil creeping along the shaft meets the teeth of the crown ring and is scraped off. The outer part of the retaining ring is formed with a shroud to enclose a water thrower clamped onto the shaft.



Figure 12

Crown Ring closure consisting of split bronze crown ring and split adapter ring.

Foundation Construction

It is important that the foundation or frame carrying the thrust bearing be adequately proportioned for the thrust. If the thrust mounting is a separate unit a bending moment is created in the sub-base or foundation. If the bearing is built into the machine frame, the frame itself must be built to carry the thrust.

Good examples of design in this respect are the welded steel plate foundation shown in the photograph, Figure 16, and the cast foundation, Figure 15, both designed for dredge pumps.

When (as often happens in ships and dredges) some degree of flexure in the foundation cannot be avoided, useful forms of mountings are those in which the thrust bearings are self-aligning. In the most commonly used type both the thrust and journal elements are self-aligning. If flexure of the shaft or foundation can occur only in the vertical plane, the adjustable two-shoe types may be used. For similar reasons it is advisable to use for propeller shaft bearings, journal bearing mountings which are self-aligning.

Although usually a journal bearing mounting will be of the size corresponding to the combined

thrust and journal bearing used with it, cases often arise where the next larger or smaller journal bearing is better suited to the duty required. A selection can usually be made from the standard journal diameters for the two units, so that both will have the same mounting number.

To secure the mountings in exact alignment, the best method is to use liners underneath, in connection with blocking keys. If the foundation is built up of structural shapes, a riveted or welded angle is used with each blocking key. This avoids the necessity for using fitted bolts. See sketches, Figure 13.

Alternative methods are to use fitted through-bolts or dowels. These are suitable for the smaller mountings or lighter thrust loads.

When they are used, the liners or shims employed to secure vertical alignment must not be thick unless the bolts or dowels are designed to resist bending. A group of thin shims is worse in this respect than one thick one. Solid liners having a thickness of one bolt diameter or more may be used, provided the bolt fits them tightly and also fits tightly in reamed holes above and below the liner.

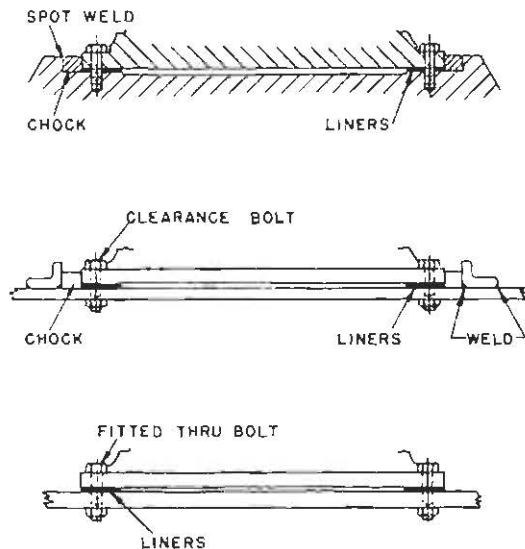
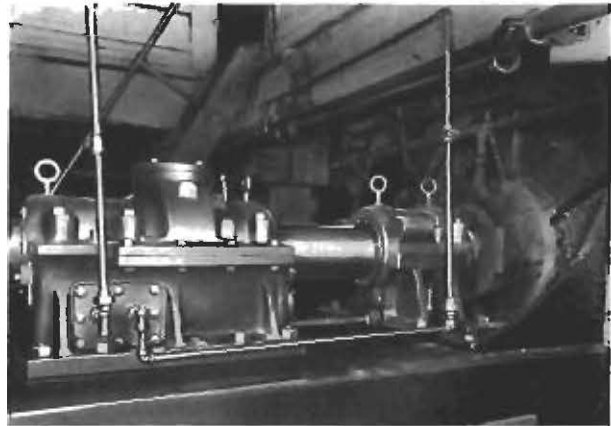

Figure 13

Various methods of securing the mountings to foundations.



Courtesy McWilliams Dredging Co.

Figure 14

Two-shoe Kingsbury Thrust Bearing, also separate Kingsbury Journal Bearing, on dredge pump shaft.

Notes on Installation

Dredge pumps are usually provided with a heavy bed plate which carries the pump body and also the bearings for the drive shaft, up to the coupling of the driving motor or engine. This assembly of course includes the thrust bearing with its accompanying journal bearing, and the journal bearing at the pump end of the shaft.

The thrust bearing and journal bearing housings are mounted on and bolted to the bed plate and must be properly lined up at assembly. The axial location of the thrust bearing is naturally determined by the required axial clearances between the pump impeller and cas-

ing, while the vertical positions of the bearings are determined by the radial clearances in the pump and by the location of the shaft axis in a plane normal to that of the pump discharge scroll.

If shims are used between the flanges of the thrust and impeller shafts, as is current practice with some designers, then the initial axial location of the thrust bearing may be a nominal one because the provision of shims of proper thickness will locate the impeller in the required position. The use of such shims also simplifies the adjustments necessary from time to time to compensate for pump liner wear and avoids disturbing the position of the bearings.

Figure 15
Six-shoe Thrust Bearing and self-aligning Journal Bearing mounted on cast dredge pump bed plate.

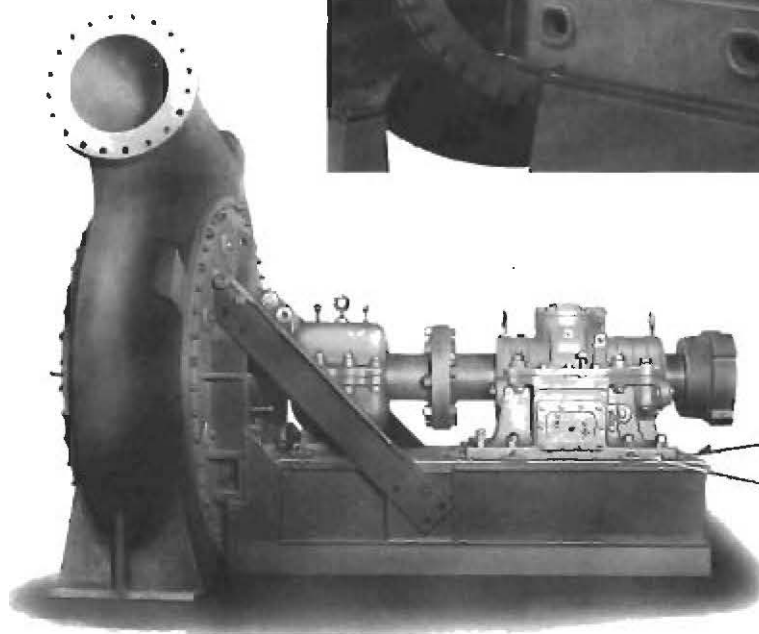
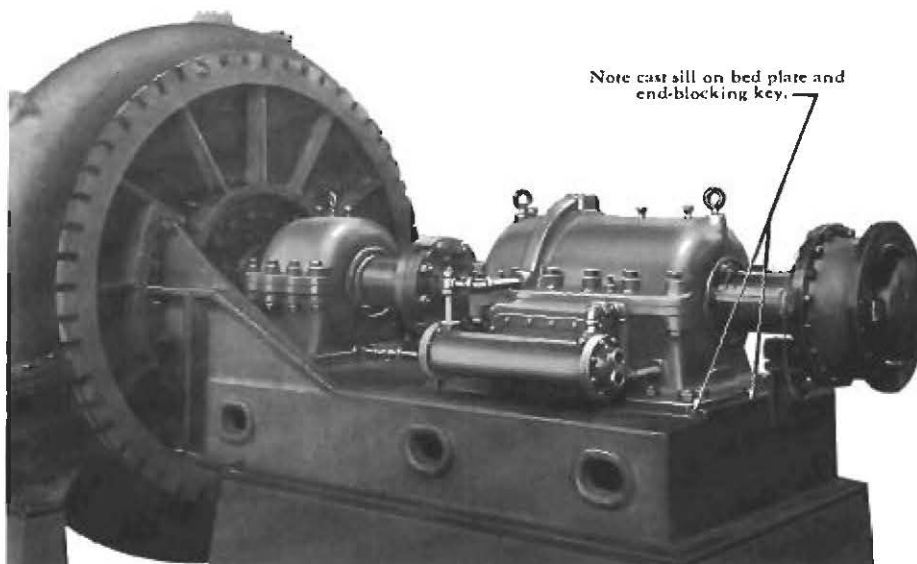

Figure 16
View of Pump with Thrust Bearing and Journal Bearing mounted on fabricated bed plate.

Note side and end blocking lugs and keys.

Courtesy Bucyrus-Erie Co

There are various methods for lining up a shaft in such an assembly and allowing for the flexure of the shaft under its own weight and it is immaterial to the supplier of the bearings which method is employed as long as the result is accurate. It should be especially noted that though Kingsbury bearings are self-aligning, either in the vertical plane or in both planes, depending on the design, that should in no

circumstances be taken as an excuse for careless workmanship and poor alignment. Faulty alignment will cause trouble regardless of the type of bearing concerned.

Detailed information regarding the procedure in the handling and assembly of the bearings themselves is furnished to each purchaser in an instruction manual prepared for his use.

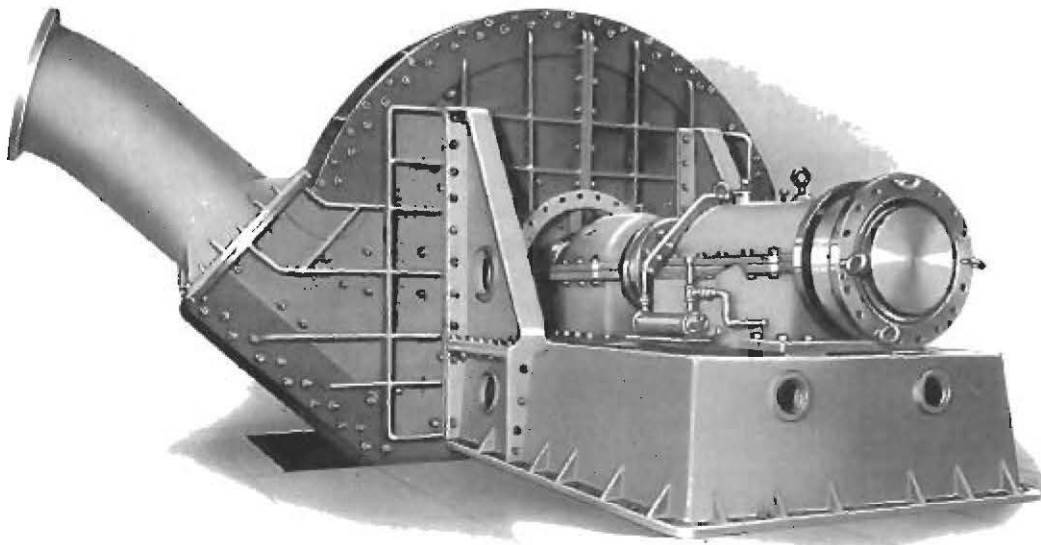

Figure 17
Large Dredge Pump bearings secured on bed plate with fitted bolts.

Courtesy Ellicott Machine Corporation

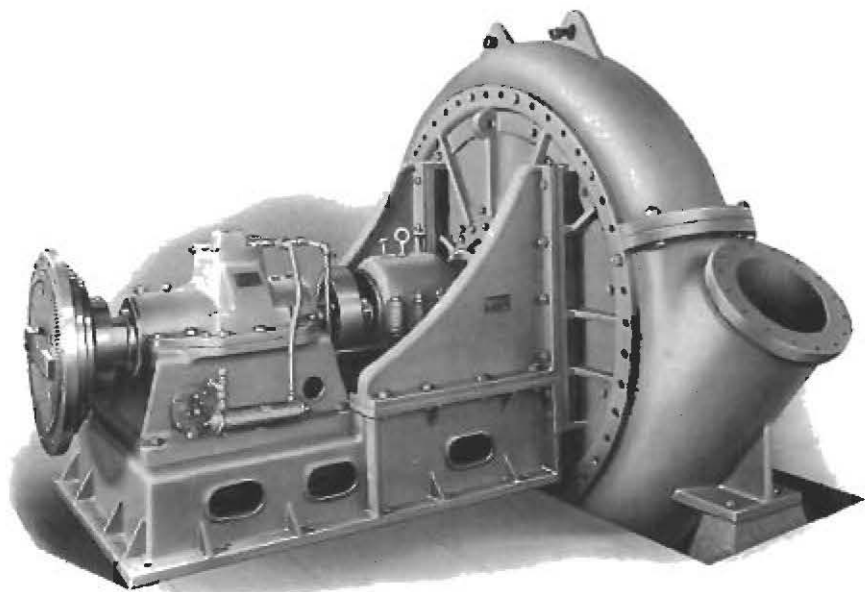

Figure 18
Smaller Pump with similar fastenings for Thrust and Journal Bearings.

Courtesy Ellicott Machine Corporation

Cutter Shaft Applications

Of equal importance to the pump which moves the dredge spoil through the pipeline to the disposal area is the cutter which breaks up

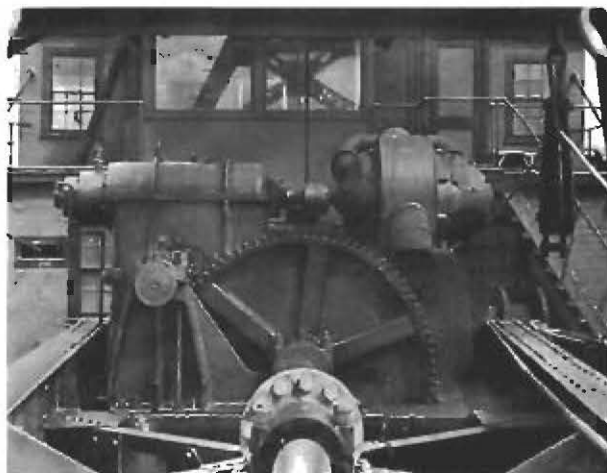

Figure 19
End on view of a typical Cutter-drive Motor and Gear Train.
(Thrust Bearing is hidden behind final gear in foreground.)

the material to be dredged and starts it through the suction pipe. The cutter shaft extends through the cutter ladder to its inboard end where it is driven by motor or engine through double reduction gears. The weight of the cutter and shaft or the net upward thrust, when the dredge is working at capacity, must be taken by a thrust bearing and here also the Kingsbury thrust bearing proves its worth.

The operating speed of the cutter is necessarily low and consequently the oil used must have a high viscosity to insure sufficiently thick oil films between the shoes and collar. Provision must also be made for an oil reservoir of such shape and capacity that the bearing cannot be starved of oil even with the cutting ladder in its extreme low position.

We have successfully engineered such applications in the past and our years of experience are the best insurance of correct design and satisfactory service.

Self-Propelled Dredge Propeller Thrusts

Because of the well-recognized superiority of Kingsbury Bearings for marine propeller thrusts, it is usual to select those bearings for self-propelled dredges. In the majority of cases the choice favors the two-shoe type of bearing, similar to that shown in Figure 6, except that the simpler form of oil scraper shown in Figure 5 and Figure 21 may be used.

Occasionally the propulsion duty is severe enough to call for a six-shoe thrust bearing. Thousands of six-shoe thrusts are in marine service: they are, in fact, the most-used Kingsbury type. With turbine drive and

geared reduction, the six-shoe bearing is nearly always built into the forward end of the gear case, where the shaft diameter can be reduced to suit the smaller collar usually required. With engine or engine-electric power, the thrust bearing is located abaft the drive. In that location, if the usual two-shoe type is deemed inadequate, a six-shoe bearing in self-contained housing may be used.

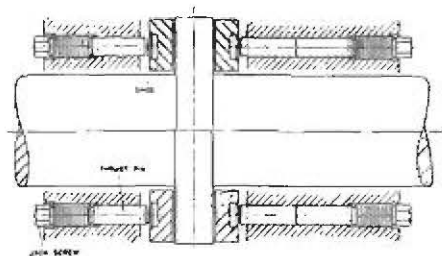

Figure 20
Two-Shoe Thrust
Plan section, showing thrust collar and shaft, shoes and jack screws.

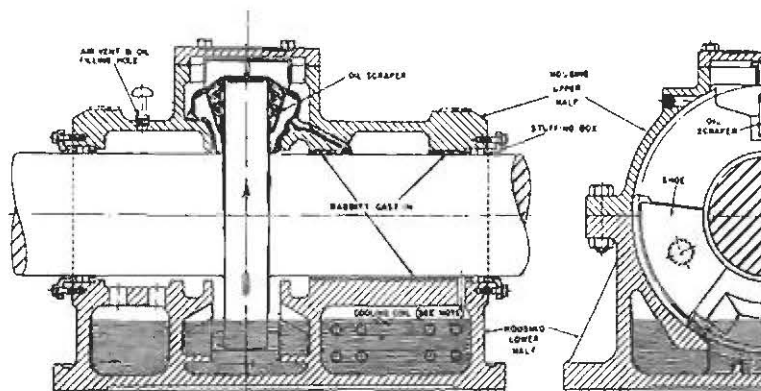

Figure 21
Two-Shoe Thrust
Vertical section, showing oil picked up by thrust collar and distributed to collar faces and journal bearing. The coil is used when the operating speed requires it.

Spare Parts

A Kingsbury Bearing correctly chosen, properly aligned and supplied with clean oil, is practically indestructible for the life of the hull. However, spare parts are customarily provided as a matter of insurance.

Spares regularly include thrust shoes, thrust collars if removable, also journal bearing shells and cooler parts where fitted.

The other parts of the bearing practically never need replacement. Therefore, there is no need to carry *complete* bearings as spares.

Data Needed for Ordering

To make specific recommendations, we should have the fullest possible information on conditions to be met, as follows:

- (A) Thrust load, maximum.
- (B) Revolutions per minute, maximum.
- (C) Shaft diameter.
- (D) Will thrust collar be integral with shaft?
- (E) Solid or split base rings? (Six-shoe only).
- (F) Is cooling water available?
- (G) Is external lubricating system available?
- (H) Give space limitations, where applicable.

If the thrust load is not known, some sort of estimate must be made.

For **propeller thrust loads**, we can make a sufficiently close estimate if given the following additional particulars:

Number of screws.

Maximum s.h.p. per shaft, and corresponding vessel speed, running free (not towing).

Propeller diameter, pitch and number of blades.

For **dredge pump thrust loads**, we should have also the pump discharge diameter, the impeller diameter, the diameter of the suction opening or "eye" in the impeller, and the horsepower of the drive.

Standard Guarantee

Any bearing or part furnished by us, which shall prove defective in design, material or workmanship, within one year after installation and test, will be replaced without charge f.o.b. Philadelphia, if returned to our factory. This period is, however, limited to a maximum of two years from the date of shipment from the fac-

tory. No allowance will be made for labor or other expense in connection therewith unless authorized in writing by an officer of the Company.

For oil coolers and cooling coils, in accordance with usual trade practice, there is no specific guarantee period.

